

JUKI®

No. 0039-05

1980-8

BE0190TOPJA

model MS-19

高速筒型二本針二重環縫ミシン

2-needle, Feed-off-The-Arm Double-Chain Stitch
Industrial Sewing Machine For Lap Seam Felling

model MS-26

高速筒型三本針二重環縫ミシン

3-needle, Feed-off-The-Arm Double-Chain Stitch
Industrial Sewing Machine For Lap Seam Felling

model MS-26G

高速筒型二本針二重環縫ミシン (厚物用・極厚物用)

2-needle, Feed-off-The-Arm Double-Chain Stitch
Industrial Sewing Machine For Lap Seam Felling
(For Heavy Weight Materials & Extra Heavy Weight Materials)

PARTS BOOK

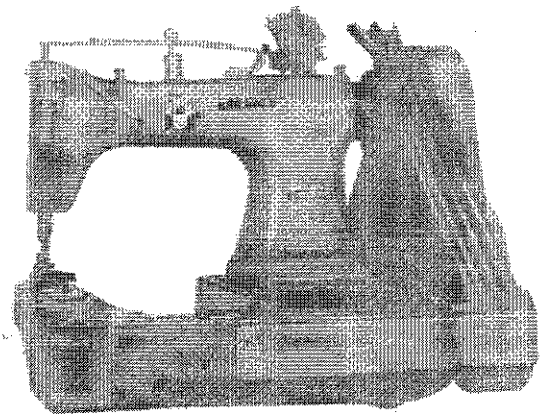
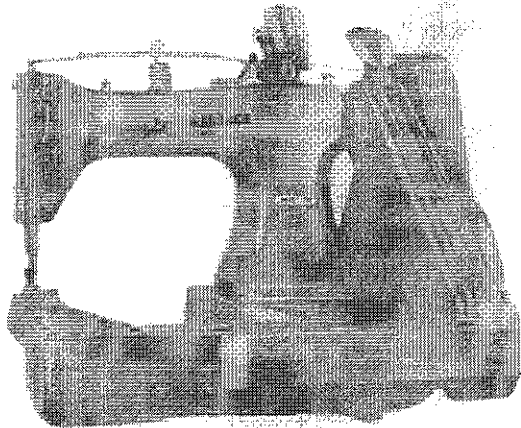

TOKYO JUKI INDUSTRIAL CO., LTD.

MS-19

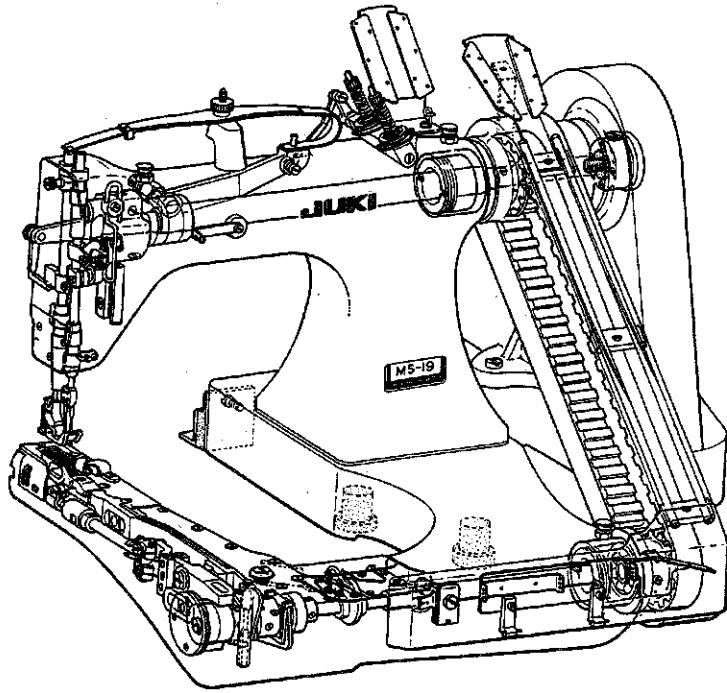

MS-26

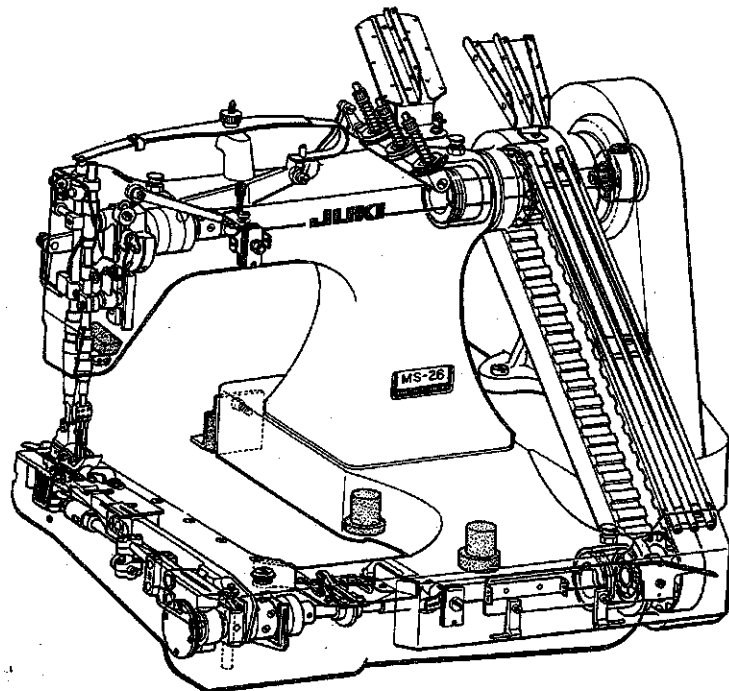

HOW TO MAKE USE OF THIS PARTS BOOK

1. As a basic principle, this parts book is divided into various sections according to the functions of respective parts.
2. The part numbers of parts shown in the figure indicate the corresponding numbers(Ref.No.) shown by the Index.
3. Explanation of codes

- 1) ① ☆ mark means this part is changed from the previous parts book.
- ② ∅01 refer to "Note" explanation at bottom of page.

2) Codes on the "E.C. (Engineering change)" column

- ① A.10/74 Added from October, 1974
- ② D.1/75 Obsoleted from January, 1975
- ③ When D.(obsoleted) and A.(added) are indicated together
D.12/74
A.12/74

④ When previous parts (Obsoleted part) and new parts (Added parts) are not interchangeable with each other:

In this case, even obsoleted parts(D.) can be ordered with the obsoleted part number, so select the parts with changed dates and place your orders.

(Example)

Ref. No.	Note	Part No.	Description	E.C.	品名	Amt. Req.
注記	品番			変更年月		数量
1	☆	B1401-100-000	Needle bar		ハリボー	—
1-1	☆	B1401-100-000-A	Needle bar	D.12/74 A.12/74	ハリボー	1

⑤ In case when previous parts and new part are interchangeable with each other:

In this case the new part number is replaced on the "品名(Japanese)" column of the previous parts, so please order by the new part number.

(Example)

Ref. No.	Note	Part No.	Description	E.C.	品名	Amt. Req.
注記	品番			変更年月		数量
1	☆	B1105-200-000	Frame cover	D.12/74	B1105-300-000	—
	☆	B1105-300-000	Frame cover	A.12/74	フレームカバー	1

④ C.3/75 This indicates error was discovered in March, 1975 and so it was corrected to a new part number.

Please note that in this case, the corrected part number is shown in the part number column and the wrong part number is shown in the "品名(Japanese)" column, so please order by the correct part number.

(Example)

Ref. No.	Note	Part No.	Description	E.C.	品名	Amt. Req.
注記	品番			変更年月		数量
1	☆	B1105-500-000	Frame cover	C.3/75	B1105-600-000	1
		↑ Correct No.			↑ Wrong No.	

⑤ M.5/75 The amount required is changed from March, 1975

The new amount required is shown in the "Amt. Req." column.

3) Codes on the "Amt. Req." column

- ① 2 Indicates amount required is 2.
- ② 2.0 Indicates length in meters. (unit is meter)
- ③ — Indicates parts obsoleted from the parts book.
- ④ (1) Indicates sub parts which construct the assembly part.

Assembly part is shown as "asm." and クミ in Japanese, in the "Description" column.

(Example)

Ref. No.	Note	Part No.	Description	E.C.	品名	Amt. Req.
注記	品番			変更年月		数量
10		B1105-900-0A0	Frame cover asm.		フレームカバー クミ	1
11		B1105-900-000	Frame cover		フレームカバー	(1)
12		SS-8110310-SP	Screw 11/64-40 L=2.8		トメネジ 11/64-40 L=2.8	(2)

When Ordering The Spare Parts:

In order to ensure that we deliver the correct parts to you, please clearly state when ordering the corresponding PART NUMBER (e.g. B1109-012-A00) and also the PARTS BOOK NUMBER (e.g. 0010-01, given at the top right of the cover) or the MACHINE SERIAL NUMBER, because there are some parts which have been changed.

パーツブックの見方

- このパーツブックは、原則として、機構別に分類された各項目からなっております。
- 図に示された部品の品番は、図にふられている No.(Ref. No.) に対応するインデックスによって、その品番がわかります。
- 記号の説明

1) "注記" 欄の記号

- ☆印……前回のパーツブックに比較して今回変更された部品を意味します。
- ◇01……ページ下の"注記"の説明を参照して下さい。

2) "変更年月" 欄の記号

- A. 10/74……1974年10月より追加された。
- D. 1/75……1975年1月より削除された。
- D. (削除)、A. (追加) が連記してある場合。
D. 12/74
A. 12/74

③ 部品の互換性がない変更の場合

この場合は削除(D)された品番でも御注文できますから、変更年月により、いずれかの部品を選択して御注文下さい。

[例]

Ref. No.	Note	Part No.	Description	E.C.	品名	Amt. Req. 数量
	注記	品番		変更年月		
1	☆	B1401-100-000	Needle bar	D.12/74	ハリボー	—
1-1	☆	B1401-100-000-A	Needle bar	A.12/74	ハリボー	1

④ 部品の互換性がある場合の変更

この場合は、旧部品の和文品名欄にそれにかわる新しい品番が記入してありますので、新しい品番で御注文下さい。

[例]

Ref. No.	Note	Part No.	Description	E.C.	品名	Amt. Req. 数量
	注記	品番		変更年月		
1	☆	B1105-200-000	Frame cover	D.12/74	B1105-300-000	—
	☆	B1105-300-000	Frame cover	A.12/74	フレームカバー	1

④ C. 3/75……1975年3月に品番のミスが判明した為、正しい品番に訂正された。

この場合は品番欄に正しい品番を、和文品名欄に間違いの品番が記入してありますので、正しい品番で御注文下さい。

[例]

Ref. No.	Note	Part No.	Description	E.C.	品名	Amt. Req. 数量
	注記	品番		変更年月		
1	☆	B1105-500-000	Frame cover	C.3/75	B1105-600-000	1
		↑	正し品番		↑	間違っていた品番

⑤ M. 5/75……1975年5月より数量が変更になった。

この場合数量欄には新しい数量が表示してあります。

3) "数量" 欄の記号

- 2……数量、2個を表わします。
- 2.0……長さ、2メートルを表わします。(単位はメートルです)
- ……このパーツブックから削除された部品です。
- (1)……組部品を構成している子部品を表わします。
組部品は品名欄に英文で"asm."和文で"クミ"と表示してあります。

[例]

Ref. No.	Note	Part No.	Description	E.C.	品名	Amt. Req. 数量
	注記	品番		変更年月		
10		B1105-900-0A0	Frame cover asm.		フレームカバー クミ	1
11		B1105-900-000	Frame cover		フレームカバー	(1)
12		SS-8110310-SP	Screw 11/64-40 L=2.8		トメネジ 11/64-40 L=2.8	(2)

補用部品注文の際の御注意

このパーツブックに記載されている補用部品を御注文の際は、部品の番号(例えば、B1109-012-A00)で御注文下さい。合わせて、御覧のパーツブックの管理番号(表紙右上、例えば、No. 0010-01)又は、機械番号を御連絡頂ければ幸いです。

改良のため部品の一部が変更になる場合がありますのでご了承下さい。

CONTENTS

目次

(MS-19)	
1. FRAME & MISCELLANEOUS COVER COMPONENTS 頭部外装関係	1
2. LOOPER THREAD GUIDE COMPONENTS カム糸案内関係	3
3. NEEDLE BAR & MAIN SHAFT COMPONENTS 針棒、上軸関係	5
4. PRESSER BAR & LOWER SHAFT COMPONENTS 押工棒、下軸関係	7
5. THREAD TENSION COMPONENTS 糸調子関係	9
6. LOOPER MECHANISM COMPONENTS ルーバ関係	10
7. FEED MECHANISM COMPONENTS 送り関係	11
(MS-26)	
8. FRAME & MISCELLANEOUS COVER COMPONENTS 頭部外装関係	13
9. LOOPER THREAD GUIDE COMPONENTS カム糸案内関係	15
10. NEEDLE BAR & MAIN SHAFT COMPONENTS 針棒、上軸関係	17
11. PRESSER BAR & LOWER SHAFT COMPONENTS 押工棒、下軸関係	19
12. THREAD TENSION COMPONENTS 糸調子関係	21
13. LOOPER MECHANISM COMPONENTS ルーバ関係	22
14. FEED MECHANISM COMPONENTS 送り関係	23
15. EXCLUSIVE PARTS FOR MODEL MS-26G MS-26G専用部品	25
16. TABLE OF EXCHANGING GAUGES FOR MS-19 MS-19交換ゲージ一覧表	27
17. TABLE OF EXCHANGING GAUGES FOR MS-26 MS-26交換ゲージ一覧表	28
18. TABLE OF EXCHANGING GAUGES FOR MS-26G MS-26G交換ゲージ一覧表	29
19. NUMERICAL INDEX OF PARTS 索引	30

Other parts books related to this model :

この機種に関連するパーツブックとして下記のパーツブックがあります。

1. MS-19/V012, MS-26/V012, MS-26G/V012 Cloth puller device
(No.0094) 先引ローラー

1. FRAME & MISCELLANEOUS COVER COMPONENTS (MS-19)

頭部外装関係 (MS-19)

Ref. No.	Note	Part No.	Description	E.C.	品名	Amt. Req.
	注記	品番		変更年月		数量
1		B3101-019-000	Face plate, upper		メンイタウエ	1
2		B3106-019-000	Screw		メンイタトメネジ	1
3		B3102-019-000	Face plate, lower		メンイタシタ	1
4		SS-1090920-SP	Screw 9/64-40 L=9.0		サラネジ 9/64-40 L=9	3
5		B3103-019-000	Gasket		メンイタパッキン	1
6		B1179-552-000	Rubber plug		アナキャップ	1
7	*	B1155-019-000	Oil cup	D.11/79	オイルカップ	1
8		B1903-019-000	Thread take-up tension lever		テンピンイトチョーシレバー	1
9		B1904-019-000	Washer		イトチョーシレバーザガネ	1
10		SS-7090710-SP	Screw 9/64-40 L=6.8		マルヒラネジ 9/64-40 L=6.8	1
11		B1146-019-000	Frame thread guide		チューカンイトアンナイ	1
12		SS-4090610-SP	Screw 9/64-40 L=6.0		ナベネジ 9/64-40 L=6	1
13		B3104-019-000	Face plate pawl spring		メンイタツメバネ	1
14		SS-7060310-SP	Screw 3/32-56 L=3.0		マルヒラネジ 3/32-56 L=3	1
15		B1130-051-000	Frame thread guide		イトアンナイ	1
16		SS-2090710-SP	Screw 9/64-40 L=7.0		マルサラネジ 9/64-40 L=7	1
17		B1157-019-000	Looper thread tube (C)		シタイトドーカン C	1
18		B1152-019-000	Rubber cushion (B)		ポーシゴム B	1
19		B1156-019-000	Rubber cushion (C)		ポーシゴム C	1
20		B1805-019-000	Lower shaft front bushing cover		シタジクマエメタルフタ	1
21		SS-6090620-SP	Screw 9/64-40 L=6.0		ヒラネジ 9/64-40 L=6	4
22		B1806-019-000	Gasket		シタジクマエメタルパッキン	1
23		B1140-019-000	Packing		アブラダメパッキン	1
24	*	B1139-019-000	Oil reservoir plug screw	D.10/79	SS-5820540-SP	1
25	*	SS-5820540-SP	Screw 1/2-28 L=5	A.10/79	トラスネジ 1/2-28 L=5	1
26		B1110-019-000	Sprocket wheel cover		スプロケットカバー	1
27		SS-8660610-TP	Screw 1/4-40 L=6.0		トメネジ 1/4-40 L=6	2
28		B2406-019-080	Looper thread tube asm.		シタイトドーカンクミ	1
29		SS-4091010-SP	Screw 9/64-40 L=10.0		ナベネジ 9/64-40 L=10	3
30		B1219-019-000	Timing belt		タイミングベルト	1
31		B1117-019-000	Sprocket wheel cover gasket		スプロケットハグルマカバーパッキン	1
32		B1111-019-000	Sprocket wheel cover plate		スプロケットカバーフタ	1
33		SS-7151210-SP	Screw 15/64-28 L=12.0		マルヒラネジ 15/64-28 L=12	2
34		B1116-019-0A0	Bed cover asm.		ベッドマドイタクミ	1
35		B1119-019-000	Bed cover gasket		マドイタパッキン	2
36		SS-7090850-SP	Screw 9/64-40 L=8.0		マルヒラネジ 9/64-40 L=8	6
37		SS-5091020-SP	Screw 9/64-40 L=9.5		トラスネジ 9/64-40 L=9.5	10
38		B1134-019-000	Oil gauge stud		ユリョーケイソクジク	1
39		B1140-019-000	Packing		アブラダメパッキン	1
40	*	B1139-019-000	Oil reservoir plug screw	D.10/79	SS-5820540-SP	1
41	*	SS-5820540-SP	Screw 1/2-28 L=5	A.10/79	トラスネジ 1/2-28 L=5	1
42		B1120-019-000	Gasket presser plate		パッキンオサエ	1
43		SS-7060310-SP	Screw 3/32-56 L=3.0		マルヒラネジ 3/32-56 L=3	1
44		B1148-019-000	Rubber cushion (A)		ポーシゴム	2
45		SS-6151440-SN	Screw 15/64-28 L=14.0		ヒラネジ 15/64-28 L=14	2
46		SK-3552000-SC	Wood screw (A) D=5.5 L=20		マルモクネジ D=5.5 L=20	2
47		B1105-019-000	Belt guard installing base		ベルトヨケダイ	1
48		SS-9284043-CP	Screw 7/16-16 L=40.0		6カクボルト 7/16-16 L=40	2
49		B1104-019-000	Belt guard		ベルトヨケ	1
50		SS-6151440-SP	Screw 15/64-28 L=14.0		ヒラネジ 15/64-28 L=14.0	2

2. LOOPER THREAD GUIDE COMPONENTS (MS-19)

カム糸案内関係 (MS-19)

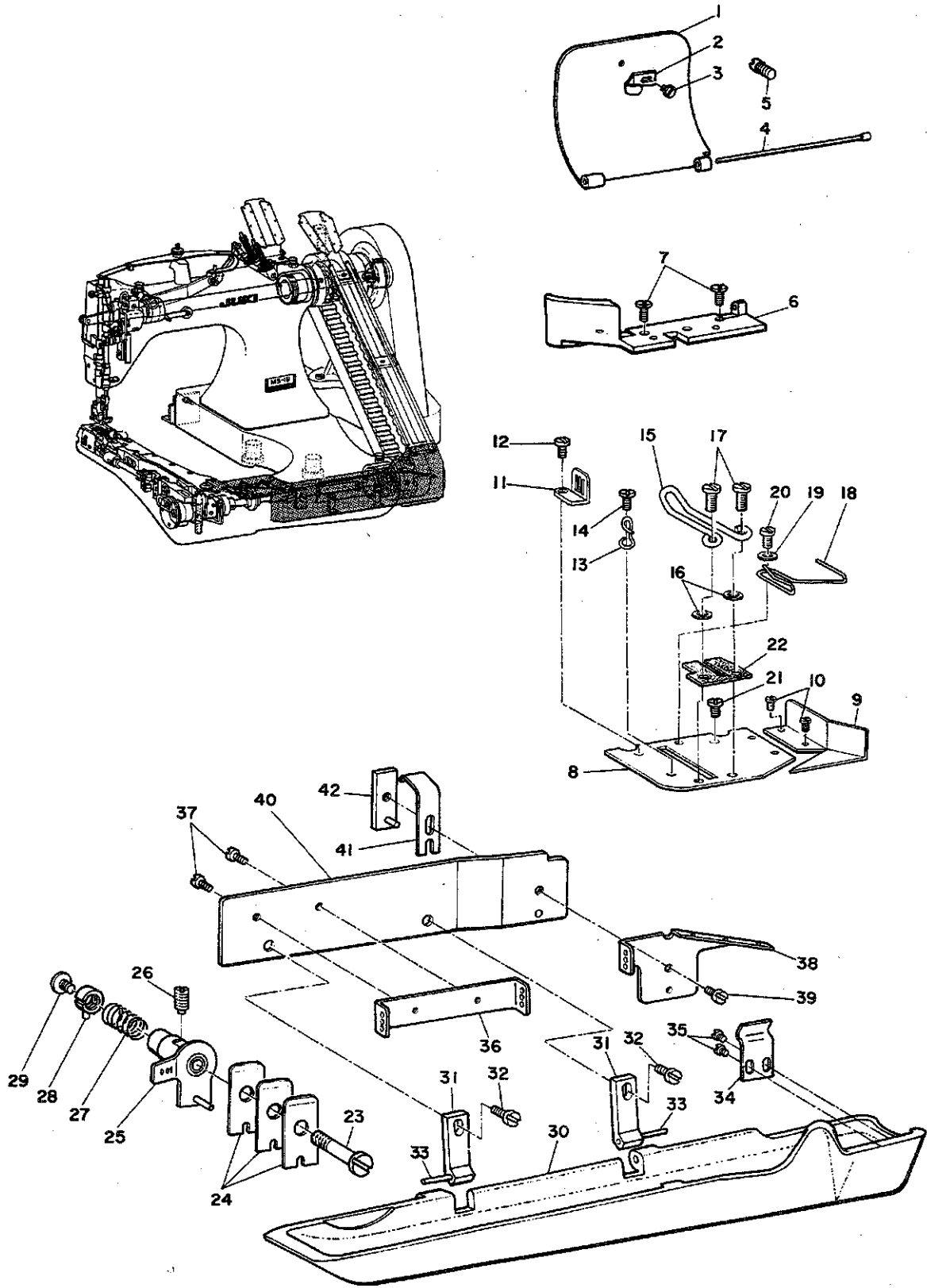

2. LOOPER THREAD GUIDE COMPONENTS (MS-19)

カム糸案内関係 (MS-19)

Ref. No.	Note	Part No.	Description	E.C.	品名	Amt. Req.
	注記	品番		変更年月		数量
1		B2207-026-000	Looper thread take-up cover		カムカバー	1
2		B2208-019-000	Looper thread take-up cover spring		カムカバーバネ	1
3		SS-6060210-SP	Screw 3/32-56 L=1.9		ヒラネジ 3/32-56 L=1.9	1
4		B2224-019-000	Looper thread take-up cover pin		カムカバーピン	1
5		B2226-019-000	Locking screw stud		カムカバーメピン	1
6		B2203-019-000	Stripper plate bracket		カムイタトリツケダイ	1
7		SS-3090510-SP	Screw 9/64-40 L=5.0		マルネジ 9/64-40 L=5	2
8		B2201-019-000	Looper thread take-up stripper plate		イトチョーシカムイタ	1
9		B2202-019-000	Thread guard		カムイトアンナイイタ	1
10		SS-6060340-SP	Screw 3/32-56 L=2.5		ヒラネジ 3/32-56 L=2.5	2
11		B2216-026-000	Looper thread guide (E)		カムイトアンナイ E	1
12		SS-7090520-SP	Screw 9/64-40 L=4.5	D.10/75	SS-7090530-SP	—
		SS-7090530-SP	Looper thread guide (C)	A.10/75	マルヒラネジ 9/64-40 L=4.5	1
13		B2213-019-000	Looper thread guide (C)		カムイトアンナイ C	1
14		SS-7090520-SP	Screw 9/64-40 L=4.5	D.10/75	SS-7090530-SP	—
		SS-7090530-SP	Looper thread guide (B)	A.10/75	マルヒラネジ 9/64-40 L=4.5	1
15		B2212-019-000	Looper thread guide (B)		カムイトアンナイ B	1
16		WP-0371016-SD	Washer 3.7 x 8.0 x 1.0		ヒラザガネ 3.7x8.0x1	2
17		SS-7090710-SP	Screw 9/64-40 L=6.8		マルヒラネジ 9/64-40 L=6.8	2
18		B2212-026-000	Looper thread guide (B)		カムイトアンナイ B	1
19		WP-0371016-SD	Washer 3.7 x 8.0 x 1.0		ヒラザガネ 3.7x8.0x1	1
20		SS-7090530-SP	Screw 9/64-40 L=4.5		マルヒラネジ 9/64-40 L=4.5	1
21		SS-7090410-SP	Screw 9/64-40 L=3.5		マルヒラネジ 9/64-40 L=3.5	1
22		B2213-038-000	Looper thread guide cushion		カムイトアンナイ B ザイタ	1
23		B2416-019-000	Looper thread tension regulating stud		シタイトチョーシイタジク	1
24		B2413-019-000	Looper thread tension plate		シタイトチョーシイタ	3
25		B2421-026-0A0	Looper thread eyelet asm.		シタイトチョーシアンナイクミ	1
26		SS-8151150-SP	Screw 15/64-28 L=10.5		トメネジ 15/64-28 L=10.5	1
27		B2415-019-000	Looper thread tension spring		シタイトチョーシバネ	1
28		B2414-019-0A0	Split nut asm.		シタイトチョーシワリナットクミ	1
29		SS-6090630-SP	Screw 9/64-40 L=6.0		ヒラネジ 9/64-40 L=6	1
30		B1113-019-000	Looper thread tube cover		シタイトドーカンカバー	1
31		B1114-019-000	Looper thread tube cover hinge		ドーカンカバーチョーバン	2
32		SS-7091110-SP	Screw 9/64-40 L=10.5		マルヒラネジ 9/64-40 L=10.5	2
33		B1115-019-000	Hinge connecting pin		チョーバンピン	2
34		B1141-019-000	Looper thread tube cover spring (A)		シタイトドーカンカバーバネ A	1
35	*	SS-7060610-SP	Screw 3/32-56 L=5.5	D.9/78	SS-7060510-SP	—
	*	SS-7060510-SP	Looper thread guide plate (A)	A.9/78	マルヒラネジ 3/32-56 L=4.8	2
36		B2413-026-A00	Looper thread guide plate (A)		シタイトアンナイイタ A	1
37		SS-7060310-SP	Screw 3/32-56 L=3.0		マルヒラネジ 3/32-56 L=3	2
38		B2413-026-B00	Looper thread guide plate (B)		シタイトアンナイイタ B	1
39		SS-3090710-TP	Screw 9/64-40 L=7.0		マルネジ 9/64-40 L=7	1
40		B2414-026-000	Looper thread guide plate base		シタイトアンナイトリツケイタ	1
41		B1143-019-000	Looper thread tube cover spring (B)		シタイトドーカンカバーバネ B	1
42		B1144-019-0A0	Reinforcing plate asm.		ドーカンカバーバネアテイタクミ	1

3. NEEDLE BAR MAIN SHAFT COMPONENTS (MS-19)

針棒、上軸関係 (MS-19)

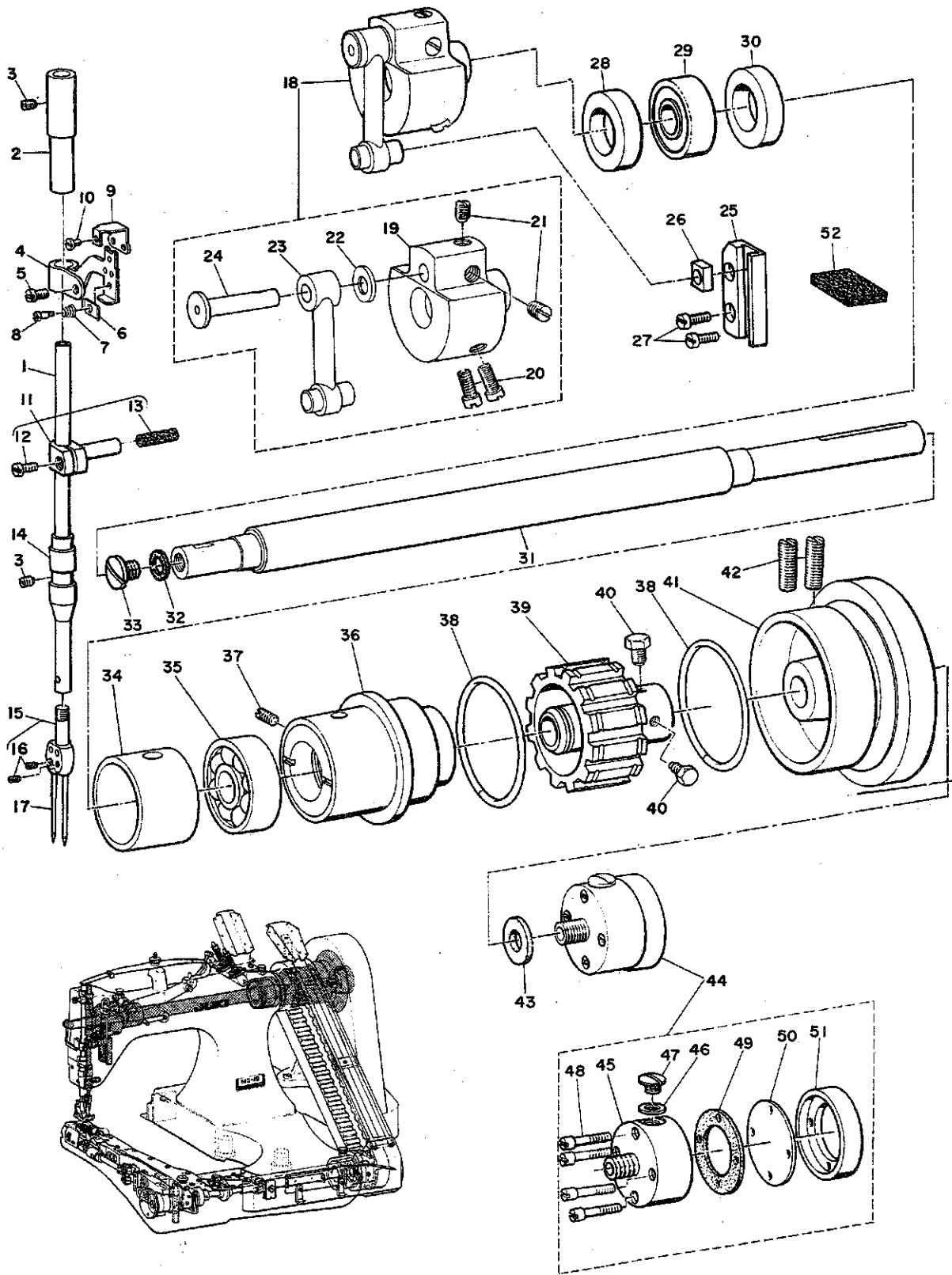

3. NEEDLE BAR MAIN SHAFT COMPONENTS (MS-19)

針棒、上軸関係 (MS-19)

Ref. No.	Note	Part No.	Description	E.C.	mmmm	Amt. Req.
	注記	品番		変更年月	品名	数量
1		B1401-019-000	Needle bar		ハリボー	1
2		B1402-019-000	Needle bar bushing, upper		ハリボーウワメタル	1
3		SS-8150310-SP	Screw 15/64-28 L=3.4		トメネジ 15/64-28 L=3.4	2
4		B1901-019-000	Thread take-up		テンピン	1
5		SS-7090910-TP	Screw 9/64-40 L=8.5		マルヒラネジ 9/64-40 L=8.5	1
6		B1908-019-000	Take-up tension plate		テンピンイトチョーシイタ	1
7		B1910-019-000	Take-up tension spring		テンピンイトチョーシバナ	1
8		SD-0280401-SL	Hinge screw D=2.80 H=4.0		ダンネジ D=2.80 H=4	1
9		B1906-019-000	Take-up thread guide		テンピンイトアンナイ	1
10		SS-3060410-SP	Screw 3/32-56 L=4.0		マルネジ 3/32-56 L=4	1
11		B1409-019-0B0	Needle bar connection asm.		ハリボーダキクミ	1
12		SS-7090910-SP	Screw 9/64-40 L=8.5		マルヒラネジ 9/64-40 L=8.5	(1)
13		B1418-019-000	Felt		ハリボーダキキューフェルト	(1)
14		B1404-026-000	Needle bar bushing, lower		ハリボーシタメタル	1
15		B1406-019-DA0	Needle clamp asm. (3/16)		ハリドメ 3/16 クミ	1
16		SS-8110310-SP	Screw 11/64-40 L=2.8		トメネジ 11/64-40 L=2.8	(2)
17		MTV-100B1600	Needle TV x 1 #16		ハリ TV x 1 #16	2
18		B1207-019-0A0-A	Counterweight asm.		ツリアイオモリクミ	1
19		B1207-019-000	Counterweight		ツリアイオモリ	(1)
20		SS-6151220-SP	Screw 15/64-28 L=11.5		ヒラネジ 15/64-28 L=11.5	(2)
21		SS-8660610-TP	Screw 1/4-40 L=6.0		トメネジ 1/4-40 L=6	(2)
22		B1208-019-000	Washer		ハリボークランクロッドザガネ	(1)
23		B1408-019-0A0	Needle bar crank rod asm.		ハリボークランクロッドクミ	(1)
24		B1209-019-0A0	Needle bar crank pin asm.		ハリボークランクピンクミ	(1)
25		B1412-038-000	Needle bar connection slide block		コロンナイダイ	1
26		B1411-019-000	Needle bar connection slide block		ハリボーダキアンナイコロ	1
27		SS-7120910-SP	Screw 3/16-28 L=9.0		マルヒラネジ 3/16-28 L=9	2
28		B1221-019-000	Oil retainer (B)		ウワジクメタルオサエ B	1
29		B1218-019-000	Ball bearing		ウワジクマエメタル	1
30		B1220-019-000	Oil retainer (A)		ウワジクメタルオサエ A	1
31		B1201-019-000	Main shaft		ウワジク	1
32		B1222-019-000	Gasket		ウワジクアブラドメカワバックン	1
33		SS-7740740-SP	Screw 3/8-28 L=6.5		マルヒラネジ 3/8-28 L=6.5	1
34		B1204-019-000	Main shaft bearing collar		ウワジクメタルブッシュ	1
35		B1202-019-000	Main shaft bearing rear		ウワジクウシロメタル	1
36		B1203-019-0A0	Main shaft bearing rear case asm.		ウワジクウシロメタルケースクミ	1
37		SS-8701140-SP	Screw 5/16-24 L=11.0		トメネジ 5/16-24 L=11	1
38		B1214-019-000	Sprocket ring		スプロケットリング	2
39		B1211-019-000	Sprocket wheel (A)		スプロケット A	1
40		SS-9150860-SP	Screw 15/64-28 L=8.0		6カクボルト 15/64-28 L=8	2
41		B1215-026-000	Hand wheel		ハズミグルマ	1
42		SS-8152030-SP	Screw 15/64-28 L=20.0		トメネジ 15/64-28 L=20	2
43		B3505-019-000	Oil cup gasket		オイルカップバックン	1
44		B3501-019-0A0	Oil cup body asm.		オイルカップクミ	1
45		B3501-019-000	Oil cup body		オイルカップタイ	(1)
46		B3508-019-000	Washer		アブラチューニューネジバックン	(1)
47		SS-5660440-SP	Screw 1/4-40 L=4.0		トラスネジ 1/4-40 L=4	(1)
48		SS-8092120-SP	Screw 9/64-40 L=21.2		ヒラネジ 9/64-40 L=21.2	(4)
49		B3503-019-000	Oil cup body cap gasket		オイルカップマドイタバックン	(1)
50		B3502-019-000	Oil cup body cap		オイルカップマドイタ	(1)
51		B3504-019-000	Oil cup body cap retainer		オイルカップフタ	(1)
52		B3510-019-000	Oil felt		カンリユーフェルト	1

4. PRESSER BAR & LOWER SHAFT COMPONENTS (MS-19)

押工棒、下軸関係 (MS-19)

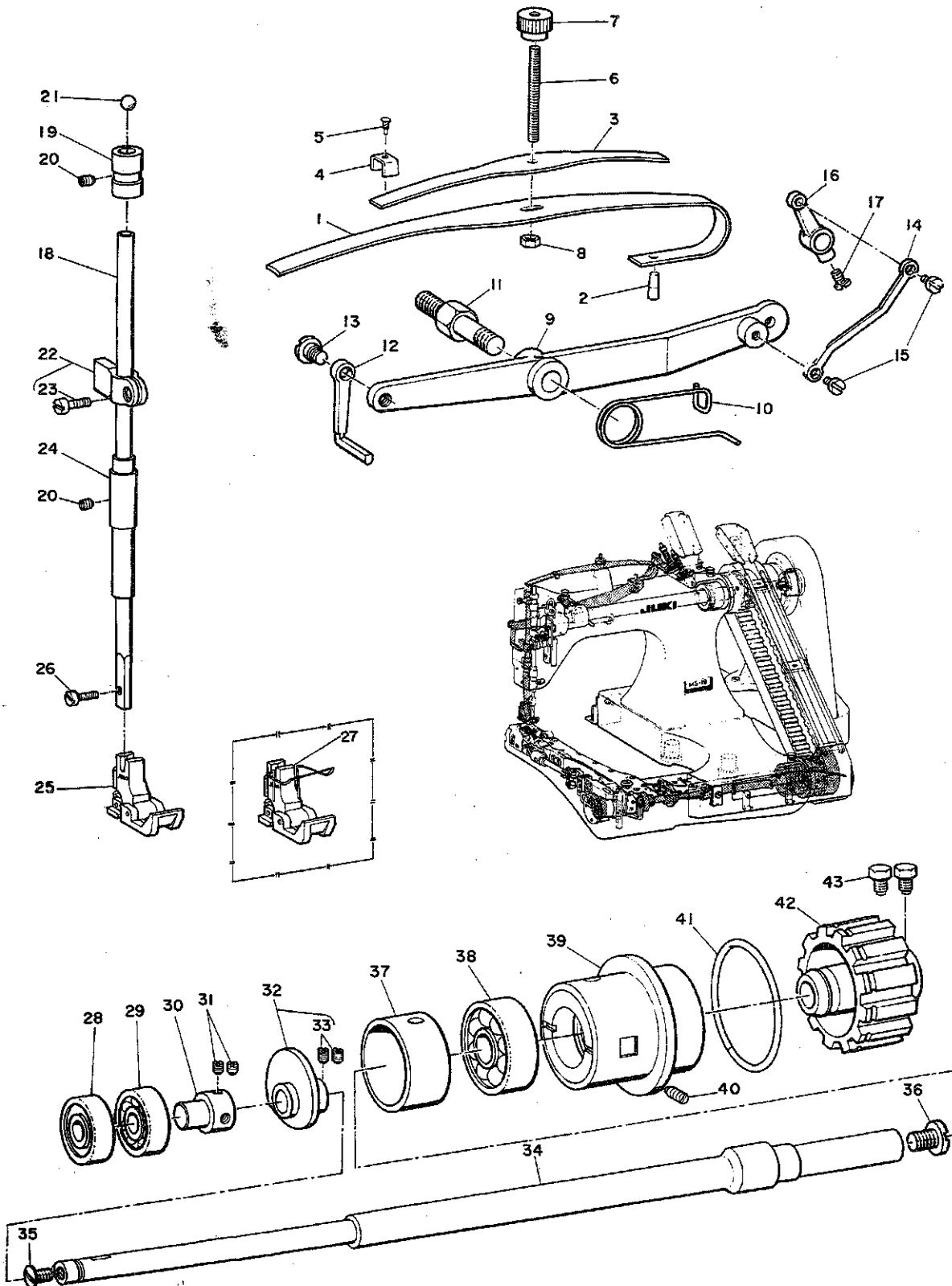

4. PRESSER BAR & LOWER SHAFT COMPONENTS (MS-19)

押工棒、下軸関係(MS-19)

Ref. No.	Note	Part No.	Description	E.C. 変更年月	品名	Amt. Req. 数量
1		B2327-019-000	Presser bar spring		オサエアゲバネ	1
2		B2328-019-000	Presser bar spring pin		オサエアゲバネピン	1
3		B2329-019-000	Presser bar spring upper		オサエアゲウバネ	1
4		B2330-019-000	Presser bar spring retainer		オサエバネトメ	1
5		B1161-012-000	Pin		ピン	1
6		B2324-019-000	Presser regulating screw		オサエチューセツネジ	1
7		B2326-019-000	Presser regulating screw nut (B)		オサエチューセツナット B	1
8		NS-6120310-SP	Nut 3/16-28		6カクナット 3/16-28	1
9		B2319-019-000	Presser bar lifting lever		ヒザアゲテコ	1
10		B2321-019-000	Presser bar lifting lever spring		ヒザアゲテコバネ	1
11		B3701-019-000	Hinge screw		ヒザアゲテコダンネジ	1
12		B2322-019-000	Presser bar lifting bracket lifter		オサエアゲテコ	1
13		SD-0790431-SP	Hinge screw D=7.94 H=4.3		ダンネジ D=7.94 H=4.3	1
14		B2315-019-000	Tension releasing connecting link		イトユルメレバー	1
15		SD-0450211-SP	Hinge screw D=4.50 H=2.1		ダンネジ D=4.50 H=2.1	2
16		B2317-019-000	Tension releasing shaft crank		イトユルメウデ	1
17		SS-7110710-SP	Screw 11/64-40 L=7.0		マルヒラネジ 11/64-40 L=7	1
18		B1501-019-000	Presser bar		オサエボー	1
19		B1502-019-000	Presser bar upper bushing		オサエボーウワメタル	1
20		SS-8150310-SP	Screw 15/64-28 L=3.4		トメネジ 15/64-28 L=3.4	2
21		B1506-019-000	Presser bar steel ball		オサエボータマ	1
22		B1504-019-0A0	Presser bar guide bracket asm.		オサエボーダキクミ	1
23		SS-7111110-TP	Screw 11/64-40 L=10.5		マルヒラネジ 11/64-40 L=10.5	(1)
24		B1503-026-000	Presser bar lower bushing		オサエボーシタメタル	1
25		B1507-019-DA0	Presser foot asm. (3/16)		オサエ 3/16 クミ	1
26		SS-7091110-SP	Screw 9/64-40 L=10.5		マルヒラネジ 9/64-40 L=10.5	1
27	◇01	B1507-019-DB0	Presser foot (finger guard) asm. (3/16)		オサエ 3/16 (ハリカバーツキ) クミ	1
28		B1802-019-000	Ball bearing, front		シタジクマエメタル	1
29		B1803-019-000	Ball bearing, intermediate		シタジクナカメタル	1
30		B1808-019-000	Sleeve		シタジクナカメタルブッシュ	1
31		SS-8110320-SP	Screw 11/64-40 L=3.2		トメネジ 11/64-40 L=3.2	2
32		B2210-019-0A0	Looper thread cam asm.		シタイトカムクミ	1
33		SS-8660330-SP	Screw 1/4-40 L=3.0		トメネジ 1/4-40 L=3	(2)
34		B1801-019-000	Lower shaft		シタジク	1
35		SS-7110830-SP	Screw 11/64-40 L=7.5		マルヒラネジ 11/64-40 L=7.5	1
36		SS-7161040-SP	Screw 1/4-24 L=9.5		マルヒラネジ 1/4-24 L=9.5	1
37		B1811-019-000	Bearing spacing collar		シタジクウシロメタルブッシュ	1
38		B1202-019-000	Main shaft bearing rear		ウワジクウシロメタル	1
39		B1810-026-0A0	Lower shaft bushing rear case asm.		シタジクウシロメタルケースクミ	1
40		SS-8701140-SP	Screw 5/16-24 L=11.0		トメネジ 5/16-24 L=11	1
41		B1214-019-000	Sprocket ring		スプロケットリング	1
42		B1212-019-000	Sprocket wheel (B)		スプロケット B	1
43		SS-9150860-SP	Screw 15/64-28 L=8.0		6カクボルト 15/64-28 L=8	2

Note (注記) ◇01 Special order part 特別注文部品です。

5. THREAD TENSION COMPONENTS (MS-19)

糸調子関係 (MS-19)

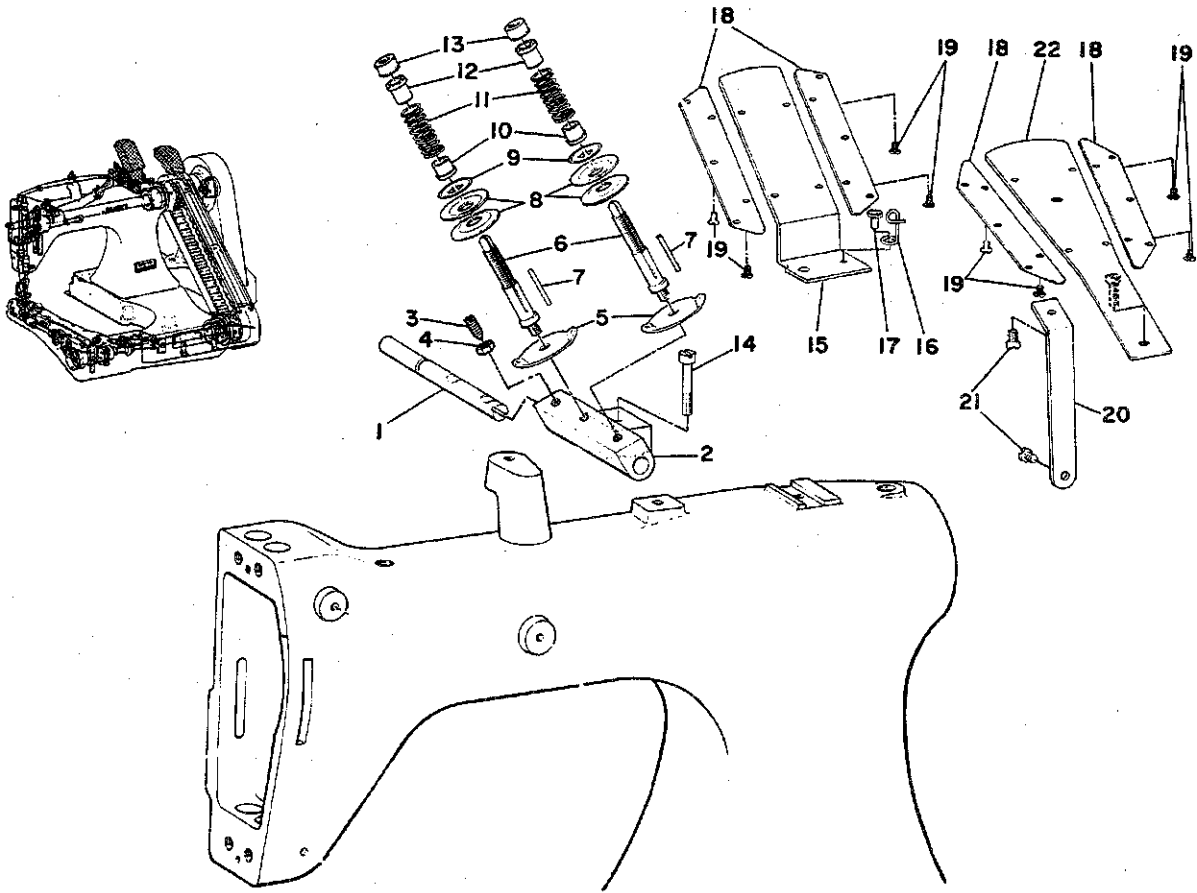

Ref. No.	Note	Part No.	Description	E.C. 変更年月	品名	Amx. Req. 数量
1		B2303-019-000	Tension release shaft		イトユルメジク	1
2		B2301-019-000	Needle thread tension bracket		イトチョーシボーダイ	1
3		SS-8111160-SP	Screw 11/64-40 L=11.0		トメネジ 11/64-40 L=11	1
4		NS-6110310-SP	Nut 11/64-40		6カクナット 11/64-40	1
5		B2306-019-000	Tension thread guide		イトチョーシアンナイタ	2
6		B2307-019-000	Tension post		イトチョーシボー	2
7		B2310-019-000	Tension releasing pin		イトユルメピン	2
8		B3126-012-000	Tension disc		イトチョーシサラ	4
9		B3132-012-000	Tension disc holder		イトチョーシサラオサエ	2
10		B2313-019-000	Tension spring bushing (B)		イトチョーシバネザ B	2
11		B2311-019-000	Tension spring		イトチョーシバネ	2
12		B2312-019-000	Tension spring bushing (A)		イトチョーシバネザ A	2
13		B2314-019-000	Tension post nut		イトチョーシボーナット	2
14		SS-4622340-SP	Screw 3/16-32 L=23.0		ナベネジ 3/16-32 L=23	1
15		B2420-019-000	Thread guide bracket		ウワイトイトアンナイタ	1
16		B2421-019-000	Thread eyelet		ウワイトイトアンナイ	1
17		SS-7090510-SP	Screw 9/64-40 L=4.6		マルヒラネジ 9/64-40 L=4.6	1
18		B2402-019-000	Thread guide		オオギイタイトアンナイ	4
19		SS-5060410-SP	Screw 3/32-56 L=3.5		マルネジ 3/32-56 L=3.5	8
20		B2404-019-000	Thread guide bracket suport		オオギイタササエ	1
21		SS-7090520-SP	Screw 9/64-40 L=4.5		マルヒラネジ 9.64-40 L=4.5	2
22		B2401-019-000	Thread guide bracket		オオギイタ	1

6. LOOPER MECHANISM COMPONENTS (MS-19)

ルーバ関係(MS-19)

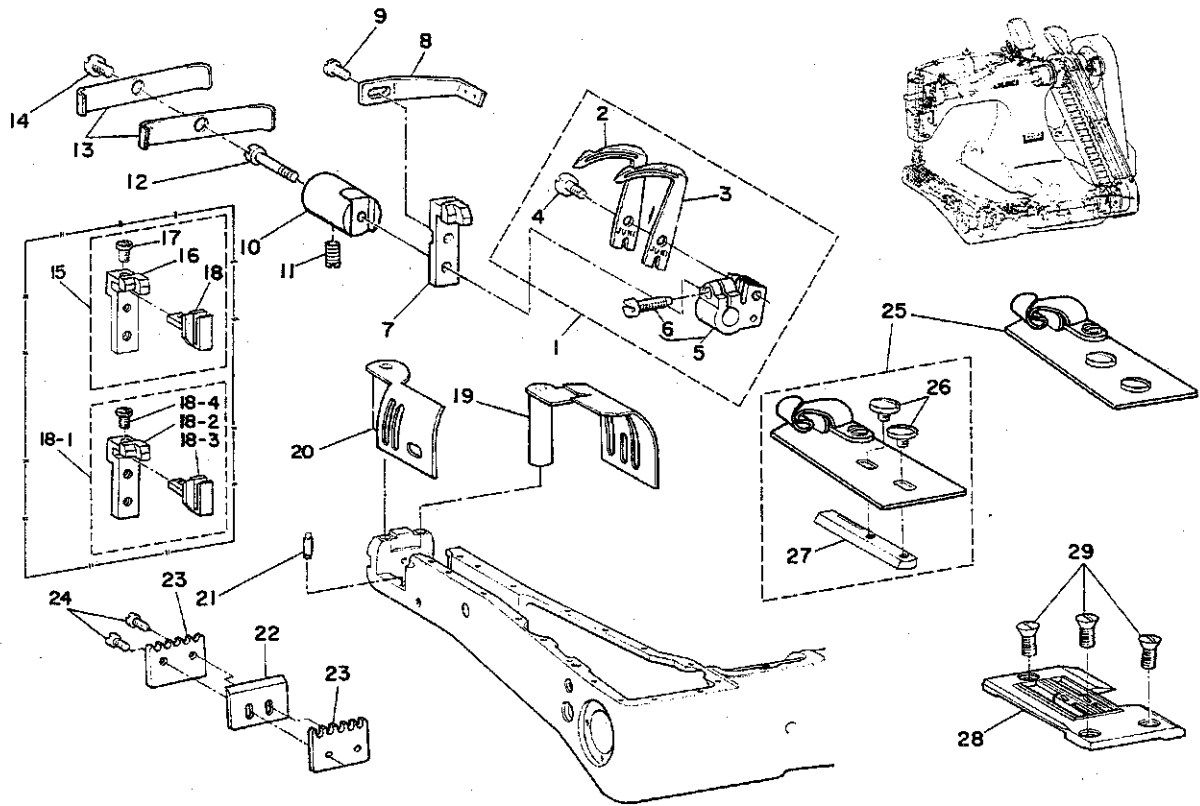

Ref. No.	Note	Part No.	Description	E.C.	Amt. Req.
注記	品番			変更年月	数量
1		B2513-019-DA0	Looper set (3/16)		1
2		B2513-019-D00	Looper (A)		(1)
3		B2514-019-D00	Looper (B)		(1)
4		SS-7091480-SP	Screw D=3.60 H=8.50		(1)
5		B2515-019-0A0	Looper holder asm.		(1)
6		SS-6111040-SP	Screw 11/64-40 L=9.5		(1)
7		B2507-019-000	Needle guard		1
8		B2510-019-000	Looper thread eyelet		1
9		SS-6080710-SP	Screw 1/8-44 L=6.5	D.11/75	-
		SS-4080610-SP	Screw 1/8-44 L=6.4	A.11/75	1
10		B2509-019-000	Needle guard holder		1
11		SS-8150410-SP	Screw 15/64-28 L=4.0		1
12		SS-7092360-SP	Screw 9/64-40 L=22.5		1
13		B1166-019-000	Looper cover spring		2
14		SS-7110710-SP	Screw 11/64-40 L=7.0		1
15	◇01	B2507-019-BA0	Needle guard (H) asm.		1
16	◇01	B2507-019-B00	Needle guard (H)		(1)
17	◇01	SS-7080510-SP	Screw 1/8-44 L=4.5		(1)
18	◇01	B2508-019-000	Auxiliary needle guard (H)		(1)
18-1	◇01	B2507-019-CA0	Needle guard (H) asm. 1/4"	A.5/78	1
18-2	◇01	B2507-019-C00	Needle guard (H) 1/4"	A.5/78	(1)
18-3	◇01	B2508-019-A00	Auxiliary needle guard (H) 1/4"	A.5/78	(1)
18-4	◇01	SS-7080510-SP	Screw 1/8-44 L=4.5	A.5/78	(1)
19		B1160-019-0A0	Looper cover asm., right		1
20		B1162-019-0A0	Looper cover asm., left		1
21		B1167-019-000	Guide pin		1
22		B1135-019-000	Thread cutter		1
23		B1137-019-000	Thread cutter holding plate		2
24		SS-3060710-SP	Screw 3/32-56 L=6.8		2
25		B9100-019-DAB	Lap seam holder (MH3/16) asm.		1
26		SS-5090320-SP	Screw 9/64-40 L=3.2		(2)
27		B9105-019-000	Lap seam holder slide plate		(1)
28		B1108-019-D00	Throat plate		1
29		SS-2110920-SP	Screw 11/64-40 L=8.5		3

Note (注記) ◇01 Special order part 特別注文部品です。

7. FEED MECHANISM COMPONENTS (MS-19)

送り関係 (MS-19)

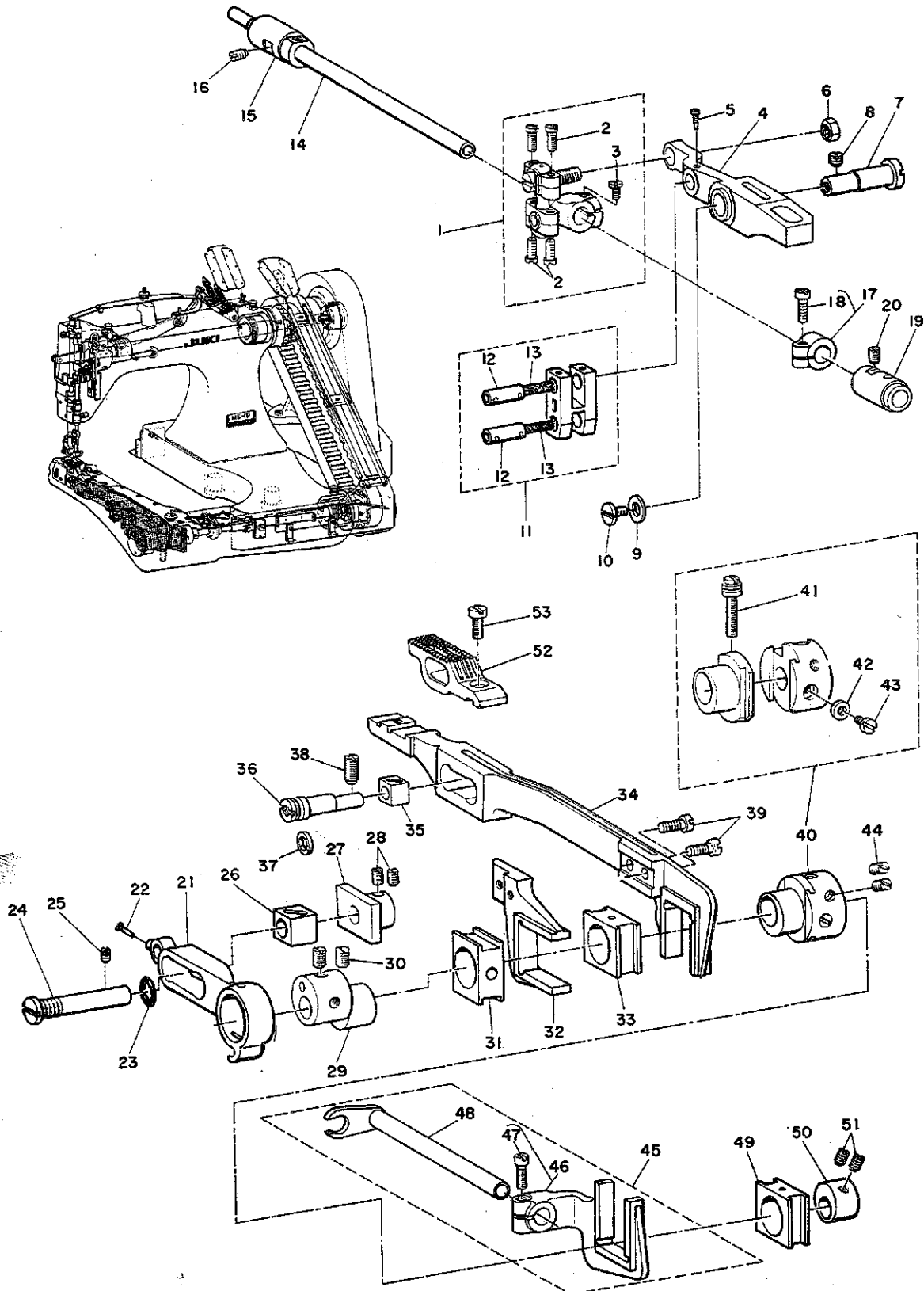

7. FEED MECHANISM COMPONENTS (MS-19)

送り関係 (MS-19)

Ref. No.	Note	Part No.	Description	E.C.	Amt. Req.
	注記	品番		変更年月	数量
1		B2109-019-0A0	Feed rocker connecting rod asm.	ヨードーレンケツカクミ	1
2		SS-7090920-SP	Screw 9/64-40 L=8.5	マルヒラネジ 9/64-40 L=8.5	(4)
3		SS-7111110-TP	Screw 11/64-40 L=10.5	マルヒラネジ 11/64-40 L=10.5	(1)
4		B2102-019-000	Feed rocker	ヨードーカン	1
5		B2117-019-000	Set screw	レンケツウデビントメネジ	1
6		NS-6150320-SP	Nut 15/64-28	6カクナット 15/64-28	1
7		B2107-019-000	Feed rocker shaft	ヨードーカンジク	1
8		SS-8150710-SP	Screw 15/64-28 L=7.0	トメネジ 15/64-28 L=7	1
9		B2122-019-000	Washer	ヨードーカンジクザガネ	1
10		SS-7110830-SP	Screw 11/64-40 L=7.5	マルヒラネジ 11/64-40 L=7.5	1
11		B2115-019-0B0	Feed rocker connecting link asm.	ヨードーレンケツウデクミ	1
12		B2116-019-000	Feed rocker connecting link pin	レンケツウデピン	(2)
13		CQ-2020000-00	Oil wick	ユシン	(0.1)
14		B2501-019-000	Looper rocker shaft	ルーバジク	1
15		B2502-019-000	Looper rocker shaft bushing, front	ルーバジクマエメタル	1
16		SS-8151150-SP	Screw 15/64-28 L=10.5	トメネジ 15/64-28 L=10.5	1
17		B2505-019-0A0	Connection crank asm.	ゼンゴカンオサエカクミ	1
18		SS-7111110-TP	Screw 11/64-40 L=10.5	マルヒラネジ 11/64-40 L=10.5	(1)
19		B2503-019-000	Looper rocker shaft bushing rear	ルーバジクウシロメタル	1
20		SS-8150410-SP	Screw 15/64-28 L=4.0	トメネジ 15/64-28 L=4	1
21		B2101-019-000	Feed rocker & looper avoid lever	ヨードーカドーカン	1
22		B2117-019-000	Screw for connecting link pin	レンケツウデビントメネジ	1
23		RO-0952001-00	Rubber ring	Oリング	1
24		B2106-019-000	Feed rocker slide block pin	ヨードーカンカクゴマジク	1
25		SS-8150410-SP	Screw 15/64-28 L=4.0	トメネジ 15/64-28 L=4	1
26		B2105-019-000	Feed rocker slide block	ヨードーカンカクゴマ	1
27		B2108-019-000	Slide block stopper	カクコマジクアテイタ	1
28		SS-8110510-SP	Screw 11/64-40 L=5.0	トメネジ 11/64-40 L=5	2
29		B2103-019-000	Feed rocker eccentric	ヨードーカンヘンシンカム	1
30		SS-8660410-SP	Screw 1/4-40 L=4.2	トメネジ 1/4-40 L=4.2	2
31		B1607-019-000	Fork slide block	フタマタサヤ	1
32		B1602-019-000	Feed lifting forked connection	ジョーゲオクリフタマタ	1
33		B1606-019-000	Feed eccentric slide block	スイヘイオクリフタマタサヤ	1
34		B1601-019-000	Feed bar	スイヘイオクリフタマタ	1
35		B1610-019-000	Feed bar hinge pin slide block	スイヘイオクリフタマタカクゴマ	1
36		B1608-019-000	Feed bar hinge pin	ジョーゲオクリチョーセツジク	1
37		B1617-019-000	Washer (Gasket)	チョーセツジクカワバッキン	1
38		SS-8151150-SP	Screw 15/64-28 L=10.5	トメネジ 15/64-28 L=10.5	1
39		SS-7111110-TP	Screw 11/64-40 L=10.5	マルヒラネジ 11/64-40 L=10.5	2
40		B1611-019-0A0	Feed eccentric asm.	スイヘイオクリチョーセツダイクミ	1
41		B1614-019-000	Regulating screw	スイヘイオクリチョーセツネジ	(1)
42		WP-0480856-SP	Washer 4.8 x 8.4 x 0.8	ヒラザガネ 4.8x8.4x0.8	(1)
43		SS-7090540-TP	Screw 9/64-40 L=5.0	マルヒラネジ 9/64-40 L=5	(1)
44		SS-8151150-SP	Screw 15/64-28 L=10.5	トメネジ 15/64-28 L=10.5	2
45		B2004-019-0B0	Looper avoiding eccentric asm.	ゼンゴカンフタマタクミ	1
46		B2004-019-0A0	Looper avoiding eccentric asm.	ゼンゴカンフタマタクミ	(1)
47		SS-7111110-TP	Screw 11/64-40 L=10.5	マルヒラネジ 11/64-40 L=10.5	(1)
48		B2001-019-000	Looper avoiding eccentric shaft	ゼンゴジク	(1)
49		B1607-019-000	Fork slide block	フタマタサヤ	1
50		B2006-019-000	Looper avoiding eccentric	ゼンゴオクリヘンシンカム	1
51		SS-8110410-TP	Screw 11/64-40 L=3.5	トメネジ 11/64-40 L=3.5	2
52		B1604-019-D00	Feed dog (3/16)	オクリバ 3/16	1
53		SS-7621040-SP	Screw 3/16-32 L=9.5	マルヒラネジ 3/16-32 L=9.5	1

8. FRAME & MISCELLANEOUS COVER COMPONENTS (MS-26)

頭部外裝關係 (MS-26)

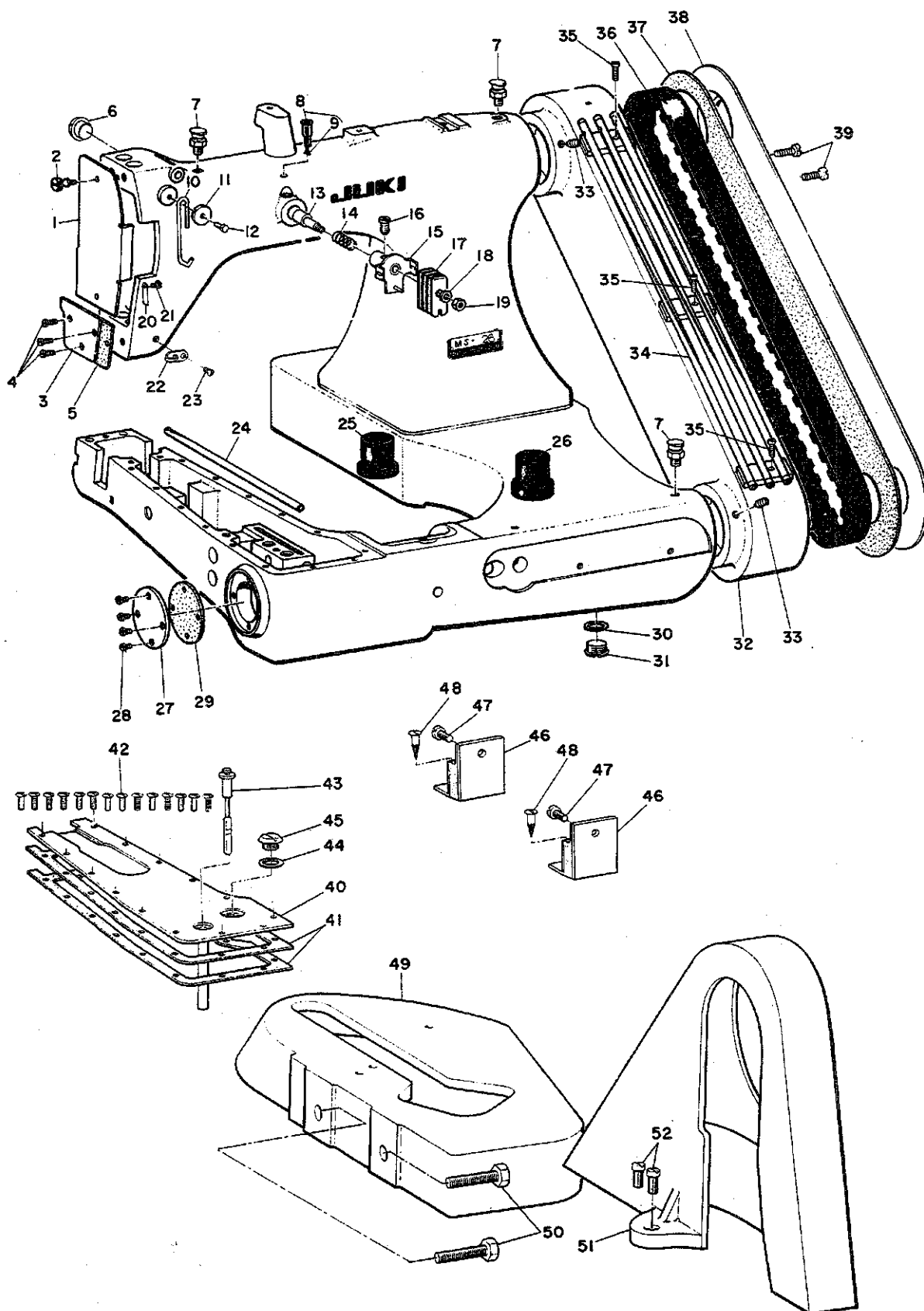

8. FRAME & MISCELLANEOUS COVER COMPONENTS (MS-26)

頭部外装関係 (MS-26)

Ref. No.	Note	Part No.	Description	E.C.	品名	Amt. Req.
	注記	品番		変更年月		数量
1		B3101-026-000	Face plate, upper		メンイタウエ	1
2		B3106-019-000	Screw		メンイタトメネジ	1
3		B3102-019-000	Face plate, lower		メンイタシタ	1
4		SS-1090920-SP	Screw 9/64-40 L=9.0		サラネジ 9/64-40 L=9	3
5		B3103-019-000	Gasket		メンイタパッキン	1
6		B1179-552-000	Rubber plug		アナキャップ	1
7	*	B1155-019-000	Oil cup	D.11/79	オイルカップ	—
8		B1156-026-0A0	Oil cup asm.		ウワイトオサエオイルカップクミ	1
9		CQ-3000000-00	Oil wick		ユシン	(0.1)
10		B1903-026-000	Thread take-up tension lever		テンピンイトチョーシレバー	1
11		B1904-019-000	Washer		イトチョーシレバーザガネ	1
12		SS-6090630-SP	Screw 9/64-40 L=6.0		ヒラネジ 9/64-40 L=6	1
13		B1143-026-0A0	Needle thread tension nipper asm.		イトオサエセッショクヘンジククミ	1
14		B1144-026-000	Nipper stud spring		イトオサエジクパネ	1
15		B1140-026-0A0	Nipper body & guide asm.		イトオサエアンナイクミ	1
16		SS-6151220-SP	Screw 15/64-28 L=11.5		ヒラネジ 15/64-28 L=11.5	1
17		B2413-019-000	Looper thread tension plate		シタイトチョーシタ	4
18		WP-0480856-SP	Washer 4.8 x 8.4 x 0.8		ヒラザガネ 4.8x8.4x0.8	1
19		NS-6110420-SP	Nut 11/64-40		6カクナット 11/64-40	1
20		B3104-019-000	Face plate pawl spring		メンイタツメパネ	1
21		SS-7060310-SP	Screw 3/32-56 L=3.0		マルヒラネジ 3/32-56 L=3	1
22		B1130-051-000	Frame thread guide, middle		イトアンナイ	1
23		SS-2090710-SP	Screw 9/64-40 L=7.0		マルサラネジ 9/64-40 L=7	1
24		B1157-019-000	Looper thread tube (C)		シタイトドーカン C	1
25		B1152-019-000	Rubber cushion (B)		ポーシソグム B	1
26		B1156-019-000	Rubber cushion (C)		ポーシソグム C	1
27		B1805-019-000	Lower shaft front bushing cover		シタジクマエメタルフタ	1
28		SS-6090620-SP	Screw 9/64-40 L=6.0		ヒラネジ 9/64-40 L=6	4
29		B1806-019-000	Gasket		シタジクマエメタルパッキン	1
30		B1140-019-000	Packing		アブラダメパッキン	1
31	*	B1139-019-000	Oil reservoir plug screw	D.10/79	SS-5820540-SP	—
32	*	SS-5820540-SP	Screw 1/2-28 L=5	A.10/79	トラスネジ 1/2-28 L=5	1
33		B1110-026-000	Sprocket wheel cover		スプロケットカバー	1
34		SS-8660610-TP	Screw 1/4-40 L=6.0		トメネジ 1/4-40 L=6	2
35		B2409-026-0B0	Looper thread tube asm.		シタイトドーカンクミ	1
36		SS-4091010-SP	Screw 9/64-40 L=10.0		ナベネジ 9/64-40 L=10	3
37		B1219-019-000	Timing belt		タイミングベルト	1
38		B1117-019-000	Sprocket wheel cover gasket		スプロケットハグルマカバーパッキン	1
39		B1111-019-000	Sprocket wheel cover plate		スプロケットカバーフタ	1
40		SS-7151210-SP	Screw 15/64-28 L=12.0		マルヒラネジ 15/64-28 L=12	2
41		B1116-026-0A0	Bed cover asm.		ベッドマドイタクミ	1
42		B1119-026-000	Bed cover gasket		マドイタパッキン	2
43		SS-5091020-SP	Screw 9/64-40 L=9.5		トラスネジ 9/64-40 L=9.5	14
44		B1134-019-000	Oil gauge stud		ユリョーケイソクジク	1
45	*	B1140-019-000	Packing		アブラダメパッキン	1
46	*	B1139-019-000	Oil reservoir plug screw	D.10/79	SS-5820540-SP	—
47	*	SS-5820540-SP	Screw 1/2-28 L=5	A.10/79	トラスネジ 1/2-28 L=5	1
48		B1148-019-000	Rubber cushion (A)		ポーシソグム	2
49		SS-6151440-SN	Screw 15/64-28 L=14.0		ヒラネジ 15/64-28 L=14	2
50		SK-3552000-SC	Wood screw (A) D=5.5 L=20		マルモクネジ D=5.5 L=20	2
51		B1105-019-000	Belt guard installing base		ベルトヨケダイ	1
52		SS-9284043-CP	Screw 7/16-16 L=40.0		6カクボルト 7/16-16 L=40	2
		B1104-019-000	Belt guard		ベルトヨケ	1
		SS-6151440-SP	Screw 15/64-28 L=14.0		ヒラネジ 15/64-28 L=14	2

9. LOOPER THREAD GUIDE COMPONENTS (MS-26)

カム糸案内関係 (MS-26)

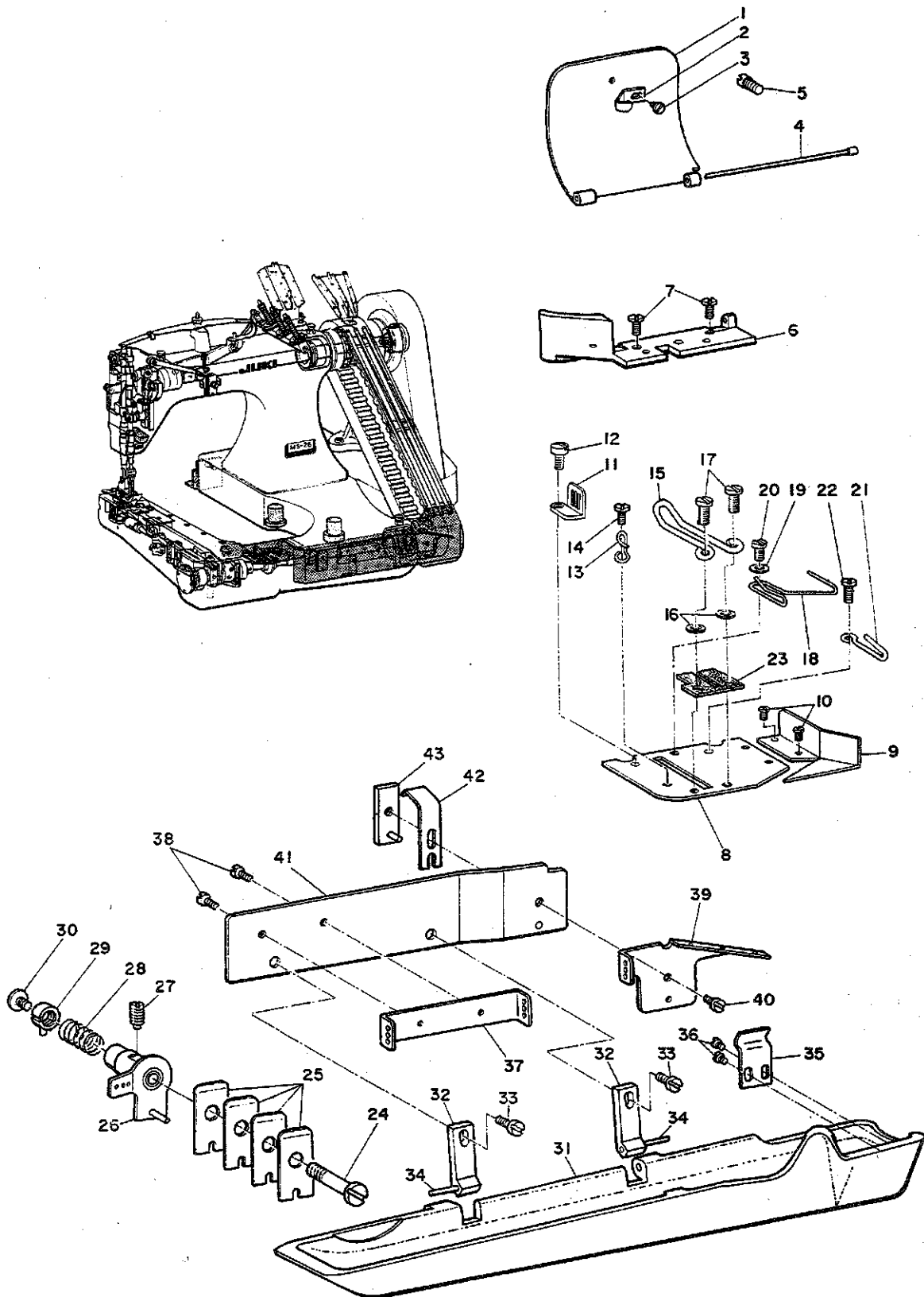

9. LOOPER THREAD GUIDE COMPONENTS (MS-26)

カム糸案内関係 (MS-26)

Ref. No.	Note	Part No.	Description	E.C.	品名	Amt. Req. 数量
	注記	品番		変更年月		
1		B2207-026-000	Looper thread take-up cover		カムカバー	1
2		B2208-019-000	Looper thread take-up cover spring		カムカバーバネ	1
3		SS-6060210-SP	Screw 3/32-56 L=1.9		ヒラネジ 3/32-56 L=1.9	1
4		B2224-019-000	Looper thread take-up cover pin		カムカバーピン	1
5		B2226-019-000	Locking screw stud		カムカバートメピン	1
6		B2203-019-000	Stripper plate bracket		カムイタトリツケダイ	1
7		SS-3090510-SP	Screw 9/64-40 L=5.0		マルネジ 9/64-40 L=5	2
8		B2201-019-000	Looper thread take-up stripper plate		イトチョーシカムイタ	1
9		B2202-019-000	Thread guard		カムイトアンナイイタ	1
10		SS-6060340-SP	Screw 3/32-56 L=2.5		ヒラネジ 3/32-56 L=2.5	2
11		B2216-026-000	Looper thread guide (E)		カムイトアンナイ E	1
12		SS-7090710-SP	Screw 9/64-40 L=6.8		マルヒラネジ 9/64-40 L=6.8	1
13		B2213-019-000	Looper thread guide (C)		カムイトアンナイ C	1
14		SS-7090520-SP	Screw 9/64-40 L=4.5	D.10/75	SS-7090530-SP	-
		SS-7090530-SP	Screw 9/64-40 L=4.5	A.10/75	マルヒラネジ 9/64-40 L=4.5	1
15		B2212-019-000	Looper thread guide (B)		カムイトアンナイ B	1
16		WP-0371016-SD	Washer 3.7 x 8.0 x 1.0		ヒラザガネ 3.7x8.0x1	2
17		SS-7090710-SP	Screw 9/64-40 L=6.8		マルヒラネジ 9/64-40 L=6.8	2
18		B2212-026-000	Looper thread guide (B)		カムイトアンナイ B	1
19		WP-0371016-SD	Washer 3.7 x 8.0 x 1.0		ヒラザガネ 3.7x8.0x1	1
20		SS-7090530-SP	Screw 9/64-40 L=4.5		マルヒラネジ 9/64-40 L=4.5	1
21		B2211-026-000	Looper thread guide (A)		カムイトアンナイ A	1
22		SS-7090710-SP	Screw 9/64-40 L=6.8		マルヒラネジ 9/64-40 L=6.8	1
23		B2213-038-000	Looper thread guide cushion		カムイトアンナイ B ザイタ	1
24		B2416-019-000	Looper thread tension regulating stud		シタイトチョーシイタジク	1
25		B2413-019-000	Looper thread tension plate		シタイトチョーシイタ	4
26		B2421-026-0A0	Looper thread eyelet asm.		シタイトチョーシアンナイクミ	1
27		SS-8151150-SP	Screw 15/64-28 L=10.5		トメネジ 15/64-28 L=10.5	1
28		B2415-019-000	Looper thread tension spring		シタイトチョーシバネ	1
29		B2414-019-0A0	Split nut asm.		シタイトチョーシワリナットクミ	1
30		SS-6090630-SP	Screw 9/64-40 L=6.0		ヒラネジ 9/64-40 L=6	1
31		B1113-019-000	Looper thread tube cover		シタイトドーカンカバー	1
32		B1114-019-000	Looper thread tube cover hinge		ドーカンカバーチョーバン	2
33		SS-7091110-SP	Screw 9/64-40 L=10.5		マルヒラネジ 9/64-40 L=10.5	2
34		B1115-019-000	Hinge connecting pin		チョーバンピン	2
35		B1141-019-000	Looper thread tube cover spring (A)		シタイトドーカンカバーバネ A	1
36	*	SS-7060610-SP	Screw 3/32-56 L=5.5	D.9/78	SS-7060510-SP	-
	*	SS-7060510-SP	Screw 3/32-56 L=4.8	A.9/78	マルヒラネジ 3/32-56 L=4.8	2
37		B2413-026-A00	Looper thread guide plate (A)		シタイトアンナイイタ A	1
38		SS-2060310-SP	Screw 3/32-56 L=3.0		マルサラネジ 3/32-56 L=3	2
39		B2413-026-B00	Looper thread guide plate (B)		シタイトアンナイイタ B	1
40		SS-3090710-TP	Screw 9/64-40 L=7.0		マルネジ 9/64-40 L=7	1
41		B2414-026-000	Looper thread guide plate base		シタイトアンナイトリツケイタ	1
42		B1143-019-000	Looper thread tube cover spring (B)		シタイトドーカンカバーバネ B	1
43		B1144-019-0A0	Reinforcing plate asm.		ドーカンカバーバネアテイタクミ	1

10. NEEDLE BAR & MAIN SHAFT COMPONENTS (MS-26)

針棒、上軸關係 (MS-26)

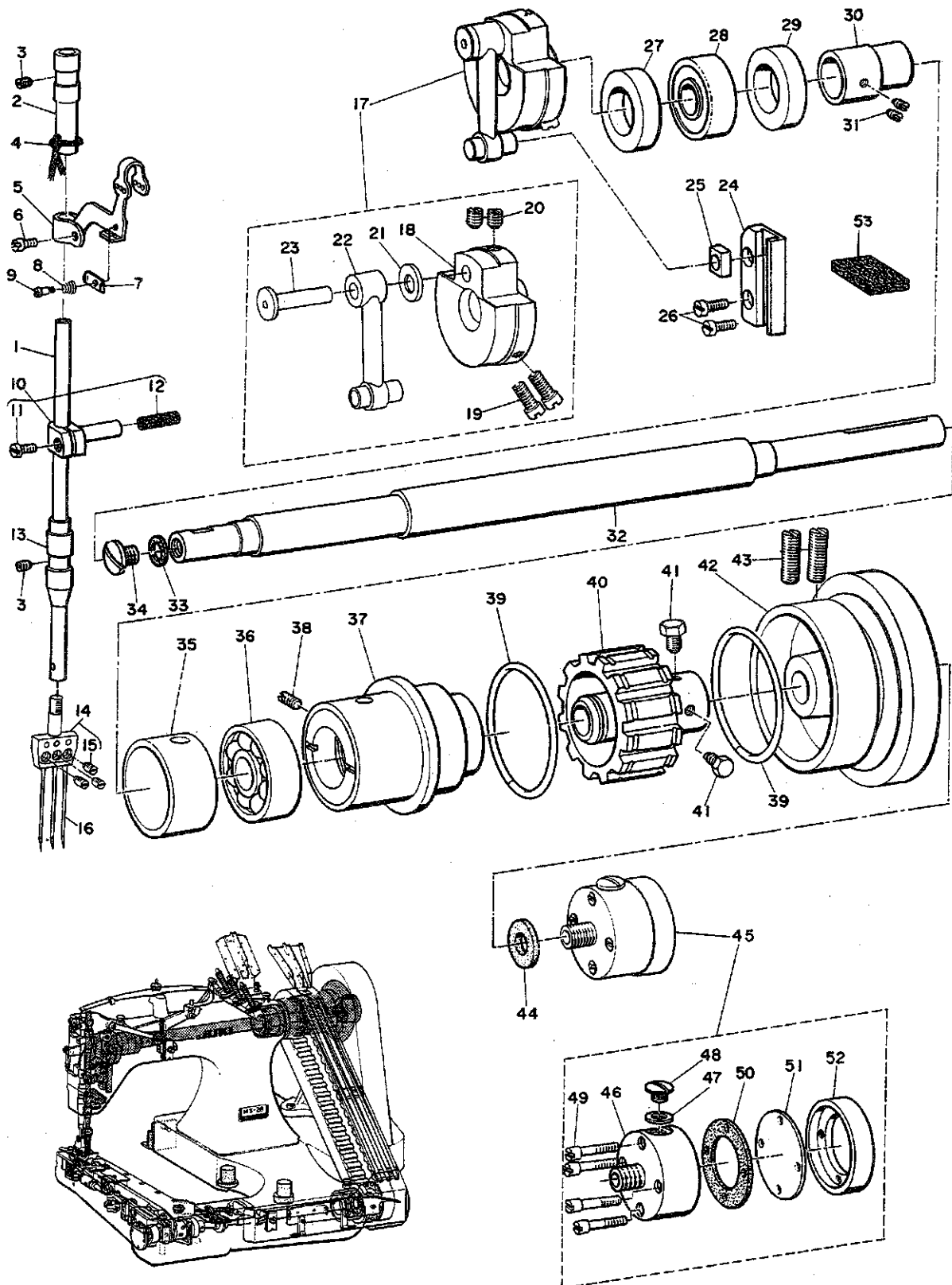

10. NEEDLE BAR & MAIN SHAFT COMPONENTS (MS-26)

針棒、上軸関係 (MS-26)

Ref. No.	Note	Part.No.	Description	E.C.	Amt. Req.
	注記	品番		変更年月	数量
1		B1401-026-000	Needle bar		1
2		B1402-026-000	Needle bar bushing, upper		1
3		SS-8150310-SP	Screw 15/64-28 L=3.4		2
4		CQ-3000000-00	Oil wick		0.2
5		B1901-026-000	Thread take-up		1
6		SS-7090910-TP	Screw 9/64-40 L=8.5		1
7		B1906-026-000	Thread take-up tension plate		1
8		B1910-019-000	Take-up tension spring		1
9		SD-0280401-SL	Hinge screw D=2.80 H=4.0		1
10		B1409-019-0B0	Needle bar connection asm.		1
11		SS-7090910-SP	Screw 9/64-40 L=8.5		(1)
12		B1418-019-000	Felt		(1)
13		B1404-026-000	Needle bar bushing, lower		1
14		B1406-026-FA0	Needle clamp asm. (1/4)		1
15		SS-8110310-SP	Screw 11/64-40 L=2.8		(3)
16		MTV-500B2104	Needle TV x 5 #21	C.3/77	3
17		B1207-026-0A0	Counterweight asm.		1
18		B1207-026-000	Counterweight		(1)
19		SS-6151220-SP	Screw 15/64-28 L=11.5		(2)
20		SS-8660410-SP	Screw 1/4-40 L=4.2		(2)
21		B1208-019-000	Washer		(1)
22		B1408-019-0A0	Needle bar crank rod asm.		(1)
23		B1209-019-0A0	Needle bar crank pin asm.		(1)
24		B1412-038-000	Needle bar connection slide block		1
25		B1411-019-000	Needle bar connection slide block		1
26		SS-7120910-SP	Screw 3/16-28 L=9.0		2
27		B1221-019-000	Oil retainer (B)		1
28		B1218-019-000	Ball bearing		1
29		B1220-019-000	Oil retainer (A)		1
30		B1222-026-000	Main shaft eccentric cam	D.5/78	—
		B1222-026-000-A	Main shaft eccentric cam	A.5/78	1
31		SS-8150410-SP	Screw 15/64-28 L=4.0		2
32		B1201-026-000	Main shaft		1
33		B1222-019-000	Gasket		1
34		SS-7740740-SP	Screw 3/8-28 L=6.5		1
35		B1204-019-000	Main shaft bearing collar		1
36		B1202-019-000	Main shaft bearing rear		1
37		B1203-019-0A0	Main shaft bushing rear case asm.		1
38		SS-8701140-SP	Screw 5/16-24 L=11.0		1
39		B1214-019-000	Sprocket ring		2
40		B1211-019-000	Sprocket wheel (A)		1
41		SS-9150860-SP	Screw 15/64-28 L=8.0		2
42		B1215-026-000	Hand wheel		1
43		SS-8152030-SP	Screw 15/64-28 L=20.0		2
44		B3505-019-000	Oil cup gasket		1
45		B3501-019-0A0	Oil cup body asm.		1
46		B3501-019-000	Oil cup body		(1)
47		B3508-019-000	Washer		(1)
48		SS-5660440-SP	Screw 1/4-40 L=4.0		(1)
49		SS-6092120-SP	Screw 9/64-40 L=21.2		(4)
50		B3503-019-000	Oil cup body cap gasket		(1)
51		B3502-019-000	Oil cup body cap		(1)
52		B3504-019-000	Oil cup body cap retainer		(1)
53		B3510-019-000	Oil felt		1

11. PRESSER BAR & LOWER SHAFT COMPONENTS (MS-26)

押工棒、下軸関係(MS-26)

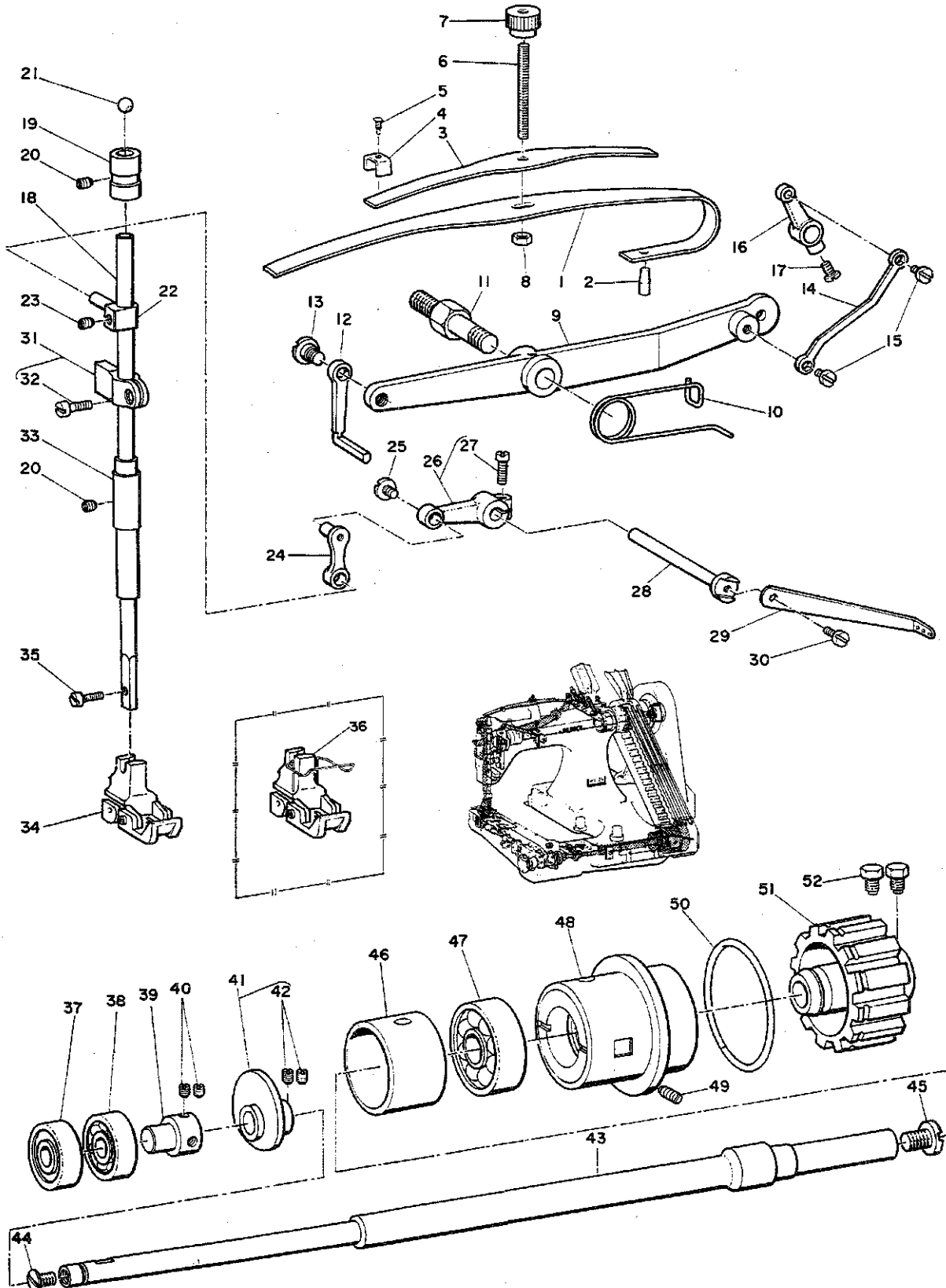

11. PRESSER BAR & LOWER SHAFT COMPONENTS (MS-26)

押工棒、下軸関係 (MS-26)

Ref. No.	Note	Part No.	Description	E.C.		Amt. Req.
	注記	品番		変更年月	品名	
1		B2327-019-000	Presser bar spring		オサエアゲバネ	1
2		B2328-019-000	Presser bar spring pin		オサエアゲバネピン	1
3		B2329-019-000	Presser bar spring upper		オサエアゲウワバネ	1
4		B2330-019-000	Presser bar spring retainer		オサエバネトメ	1
5		B1161-012-000	Pin		ピン	1
6		B2324-019-000	Presser regulating screw		オサエチューセツネジ	1
7		B2326-019-000	Presser regulating screw nut (B)		オサエチューセツナット B	1
8		NS-6120310-SP	Nut 3/16-28		6カクナット 3/16-28	1
9		B2319-019-000	Presser bar lifting lever		ヒザアゲテコ	1
10		B2321-019-000	Presser bar lifting lever spring		ヒザアゲテコバネ	1
11		B3701-019-000	Hinge screw		ヒザアゲテコダンネジ	1
12		B2322-019-000	Presser bar lifting bracket lifter		オサエアゲテコ	1
13		SD-0790431-SP	Hinge screw D=7.94 H=4.3		ダンネジ D=7.94 H=4.3	1
14		B2315-019-000	Tension releasing connecting link		イトユルメレバー	1
15		SD-0450211-SP	Hinge screw D=4.50 H=2.1		ダンネジ D=4.50 H=2.1	2
16		B2317-019-000	Tension releasing shaft crank		イトユルメウデ	1
17		SS-7110710-SP	Screw 11/64-40 L=7.0		マルヒラネジ 11/64-40 L=7	1
18		B1501-019-000	Presser bar		オサエボー	1
19		B1502-019-000	Presser bar upper bushing		オサエボーウワメタル	1
20		SS-8150310-SP	Screw 15/64-28 L=3.4		トメネジ 15/64-28 L=3.4	2
21		B1506-019-000	Presser bar steel ball		オサエボータマ	1
22		B1159-026-000	Bracket		チューカンイトユルメピン	1
23		SS-8150410-SP	Screw 15/64-28 L=4.0		トメネジ 15/64-28 L=4	1
24		B1161-026-000	Tension release link		チューカンイトユルメリンク	1
25		SS-5090710-SP	Screw 9/64-40 L=6.5		トラスネジ 9/64-40 L=6.5	1
26		B1162-026-0A0	Tension release arm asm.		チューカンイトユルメウデクミ	1
27		SS-4091010-SP	Screw 9/64-40 L=10.0		ナベネジ 9/64-40 L=10	(1)
28		B1164-026-000	Tension release lever shaft		チューカンイトユルメジク	1
29		B1165-026-000	Tension release lever		チューカンイトユルメレバー	1
30		SS-7090710-SP	Screw 9/64-40 L=6.8		マルヒラネジ 9/64-40 L=6.8	1
31		B1504-019-0A0	Presser bar guide bracket asm.		オサエボーダキクミ	1
32		SS-7111110-TP	Screw 11/64-40 L=10.5		マルヒラネジ 11/64-40 L=10.5	(1)
33		B1503-026-000	Presser bar lower bushing		オサエボーシタメタル	1
34		B1507-026-FA0	Presser foot asm. (1/4)		オサエ 1/4 クミ	1
35		SS-7091110-SP	Screw 9/64-40 L=10.5		マルヒラネジ 9/64-40 L=10.5	1
36	◇01	B1507-026-FB0	Presser foot (FINGER GUARD) asm. (1/4)		オサエ 1/4 (ハリカバーツキ) クミ	1
37		B1802-019-000	Ball bearing, front		シタジクマメタル	1
38		B1803-019-000	Ball bearing, intermediate		シタジクナカメタル	1
39		B1808-019-000	Sleeve		シタジクナカメタルブッシュ	1
40		SS-8110320-SP	Screw 11/64-40 L=3.2		トメネジ 11/64-40 L=3.2	2
41		B2210-019-0A0	Looper thread cam asm.		シタイトカムクミ	1
42		SS-8660330-SP	Screw 1/4-40 L=3.0		トメネジ 1/4-40 L=3	(2)
43		B1801-026-000	Lower shaft		シタジク	1
44		SS-7110830-SP	Screw 11/64-40 L=7.5		マルヒラネジ 11/64-40 L=7.5	1
45		SS-7161040-SP	Screw 1/4-24 L=9.5		マルヒラネジ 1/4-24 L=9.5	1
46		B1811-019-000	Bearing spacing collar		シタジクウシロメタルブッシュ	1
47		B1202-019-000	Main shaft bearing rear		ウワジクウシロメタル	1
48		B1810-026-0A0	Lower shaft bushing rear case asm.		シタジクウシロメタルケースクミ	1
49		SS-8701140-SP	Screw 5/16-24 L=11.0		トメネジ 5/16-24 L=11	1
50		B1214-019-000	Sprocket ring		スプロケットリング	1
51		B1212-019-000	Sprocket wheel (B)		スプロケット B	1
52		SS-9150860-SP	Screw 15/64-28 L=8.0		6カクボルト 15/64-28 L=8	2

Note (注記) ◇01 Special order part 特別注文品です。

13. LOOPER MECHANISM COMPONENTS (MS-26)

ルーパ関係 (MS-26)

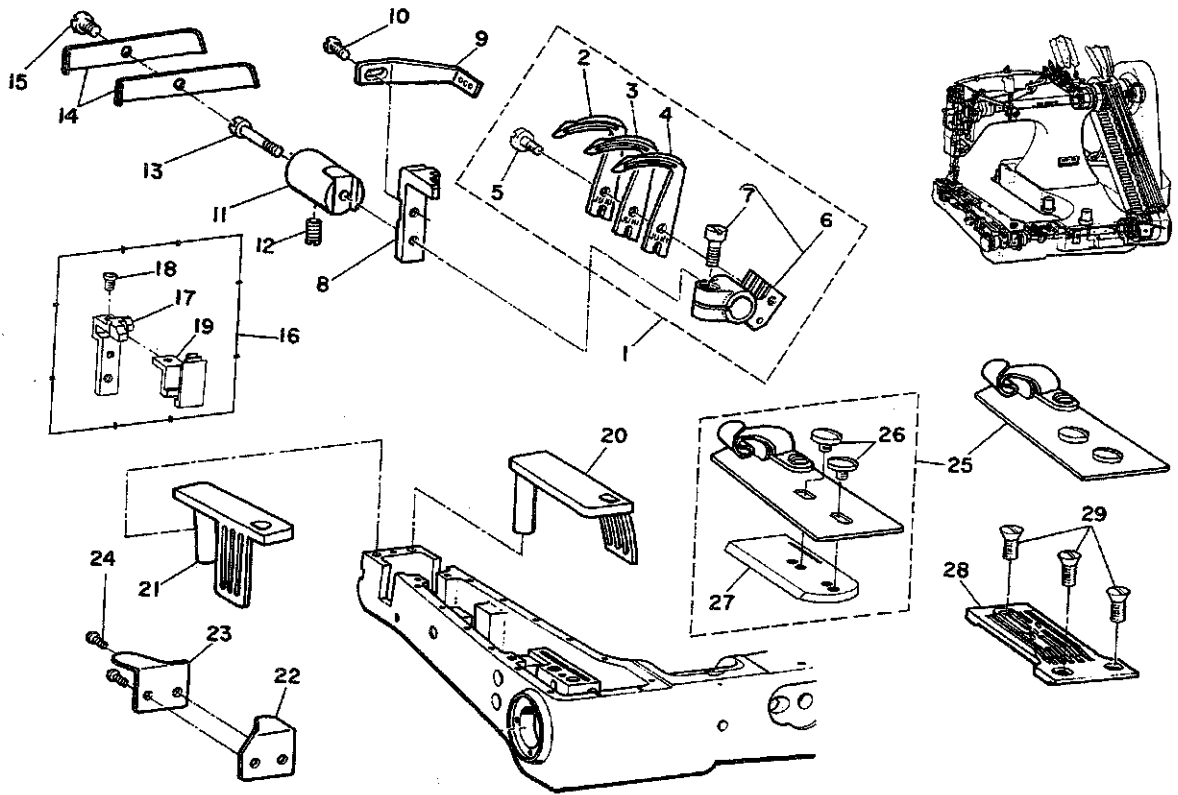

Ref. No.	Note	Part No.	Description	E.C.	Amt. Req.
注記	品番			変更年月	数量
1		B2513-026-FA0	Looper set (1/4)		1
2		B2513-026-F00	Looper (A)		(1)
3		B2514-026-000	Looper (B)		(1)
4		B2515-026-F00	Looper (C)		(1)
5		B2518-026-000	Screw		(1)
6		B2516-026-0A0	Looper holder asm.		(1)
7		SS-6111040-SP	Screw 11/64-40 L=9.5		(1)
8		B2507-026-000	Needle guard		1
9		B2510-026-000	Looper thread eyelet		1
10		SS-6080710-SP	Screw 1/8-44 L=6.5	D.11/75	—
		SS-4080610-SP	Screw 1/8-44 L=6.4	A.11/75	1
11		B2509-019-000	Needle guard holder		1
12		SS-8150410-SP	Screw 15/64-28 L=4.0		1
13		SS-7092360-SP	Screw 9/64-40 L=22.5		1
14		B1127-026-000	Looper gate retaining spring		1
15		SS-7090710-SP	Screw 9/64-40 L=6.8		2
16	001	B2507-026-CA0	Needle guard (H) asm.		1
17	001	B2507-026-C00	Needle guard (H)		1
18	001	SS-6080610-TP	Screw 1/8-44 L=6.0		(1)
19	001	B2508-026-000	Auxiliary needle guard (H)		(1)
20		B1122-026-0A0	Looper gate asm., right		(1)
21		B1125-026-0A0	Looper gate asm., left		1
22		B1130-026-000	Chain cutter blade (A)		1
23		B1131-026-000	Chain cutter blade (B)		1
24		SS-3060710-SP	Screw 3/32-56 L=6.8		1
25		B9100-026-FAB	Lap seam holder (MH1/4) asm.		2
26		SS-5090320-SP	Screw 9/64-40 L=3.2		1
27		B9105-026-000	Lap seam holder slide plate		(2)
28		B1108-026-F00	Throat plate (1/4)		(1)
29		SS-2110920-SP	Screw 11/64-40 L=8.5		1
					3

Note (注記) 001 Special order part 特別注文品です。

14. FEED MECHANISM COMPONENTS (MS-26)

送り関係 (MS-26)

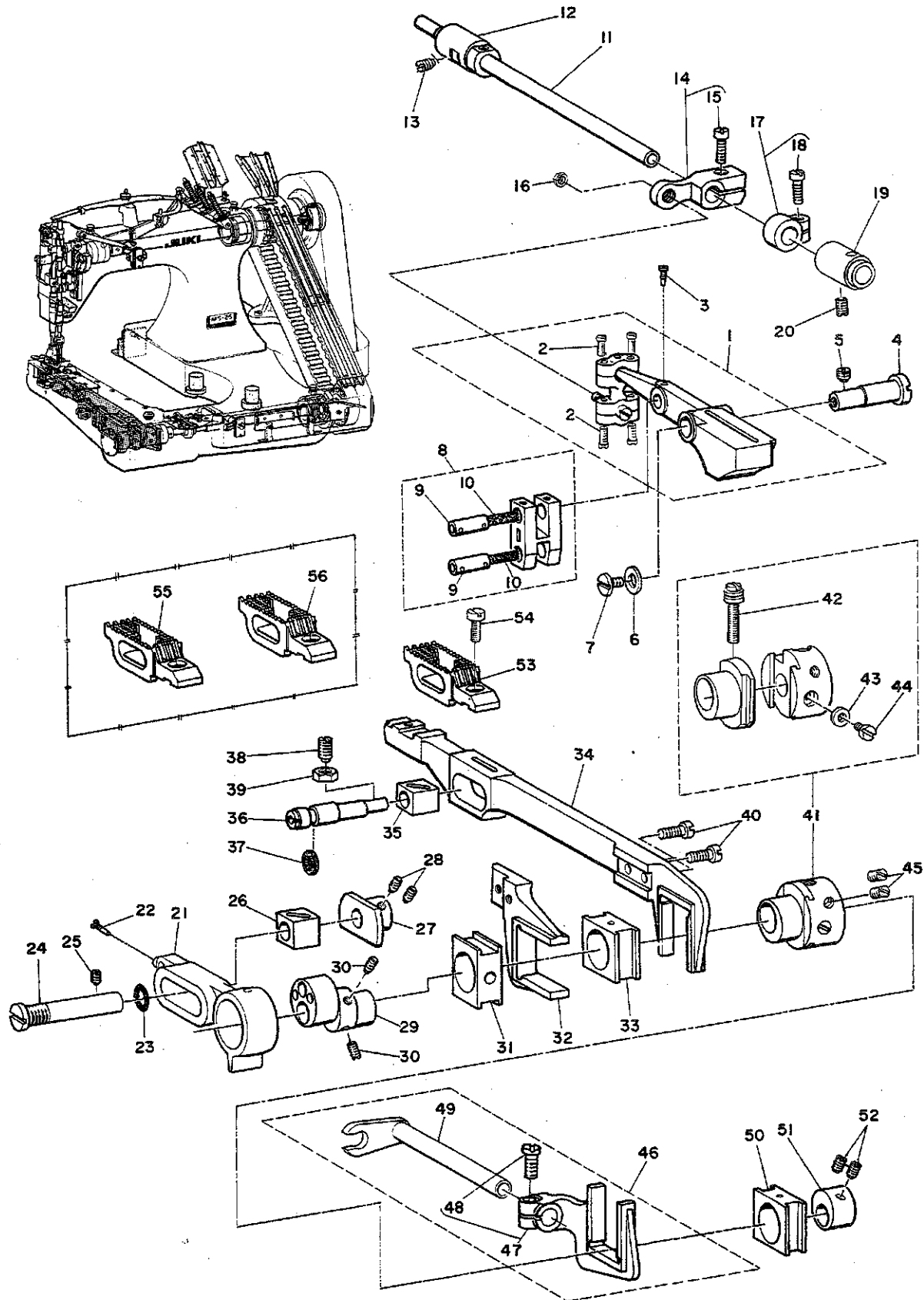

14. FEED MECHANISM COMPONENTS (MS-26)

送り関係 (MS-26)

Ref. No.	Note	Part No.	Description	E.C.	Amt. Req.
	注記	品番		変更年月	数量
1		B2102-026-0A0	Feed rocker asm.		1
2		SS-7090920-SP	Screw 9/64-40 L=8.5		(4)
3		B2117-019-000	Screw for connecting link pin		1
4		B2107-019-000	Feed rocker shaft		1
5		SS-8150710-SP	Screw 15/64-28 L=7.0		1
6		B2122-019-000	Washer		1
7		SS-7110830-SP	Screw 11/64-40 L=7.5		1
8		B2115-019-0B0	Feed rocker connecting link asm.		1
9		B2116-019-000	Feed rocker connecting link pin		1
10		CQ-2020000-00	Oil wick		(2)
11		B2501-026-000	Looper rocker shaft		(0.1)
12		B2502-019-000	Looper rocker shaft bushing, front		1
13		SS-8151150-SP	Screw 15/64-28 L=10.5		1
14		B2123-026-0A0	Feed rocker asm.		1
15		SS-7111110-TP	Screw 11/64-40 L=10.5		1
16		NS-8150320-SP	Nut 15/64-28		(1)
17		B2505-019-0A0	Connection crank asm.		1
18		SS-7111110-TP	Screw 11/64-40 L=10.5		1
19		B2503-019-000	Looper rocker shaft bushing rear		(1)
20		SS-8150310-SP	Screw 15/64-28 L=3.4		1
21		B2101-026-000	Slide block pin		1
22		B2117-019-000	Set screw		1
23		RO-0952001-00	Rubber ring		1
24		B2106-026-000	Slide block pin		1
25		SS-8150410-SP	Screw 15/64-28 L=4.0		1
26		B2105-019-000	Feed rocker slide block		1
27		B2108-026-000	Slide block stopper		1
28		SS-8110510-SP	Screw 11/64-40 L=5.0		1
29		B2103-026-000	Feed rocker eccentric		2
30		SS-8660410-SP	Screw 1/4-40 L=4.2		1
31		B1607-019-000	Fork slide block		2
32		B1602-019-000	Feed lifting forked connection		1
33		B1606-019-000	Feed eccentric slide block		1
34		B1601-026-000	Feed bar		1
35		B1610-019-000	Feed bar hinge pin slide block		1
36		B1608-026-000	Feed bar hinge pin		1
37		B1617-019-000	Washer (Gasket)		1
38		SS-8151150-SP	Screw 15/64-28 L=10.5		1
39		NS-8150320-SP	Nut 15/64-28		1
40		SS-7111110-TP	Screw 11/64-40 L=10.5		1
41		B1611-019-0A0	Feed eccentric asm.		2
42		B1614-019-000	Feed regulating screw		1
43		WP-0480856-SP	Washer 4.8 x 8.4 x 0.8		(1)
44		SS-7090540-TP	Screw 9/64-40 L=5.0		(1)
45		SS-8151150-SP	Screw 15/64-28 L=10.5		(1)
46		B2001-026-0C0	Looper avoiding shaft asm.		2
47		B2001-026-0B0	Looper avoiding shaft asm.		1
48		SS-7111110-TP	Screw 11/64-40 L=10.5		(1)
49		B2002-026-000-A	Looper avoiding shaft bracket		(1)
50		B1607-019-000	Fork slide block		(1)
51		B2006-019-000	Looper avoiding eccentric		1
52		SS-8110410-TP	Screw 11/64-40 L=3.5		1
53		B1604-026-A00	Feed dog (7/32", 1/4", 9/32")		2
54		SS-7621040-SP	Screw 3/16-32 L=9.5		1
55	◇01	B1604-026-A0H	Feed dog (H)		1
56	◇01	B1604-026-B0H	Feed dog (H)		1

Note (注記) ◇01....Special order parts 特別注文品です。

15. EXCLUSIVE PARTS FOR MODEL MS-26G

MS-26G専用部品

1. COMMON PARTS FOR GAUGE 1/4", 5/16"

ゲージ1/4"、5/16" 共通部品

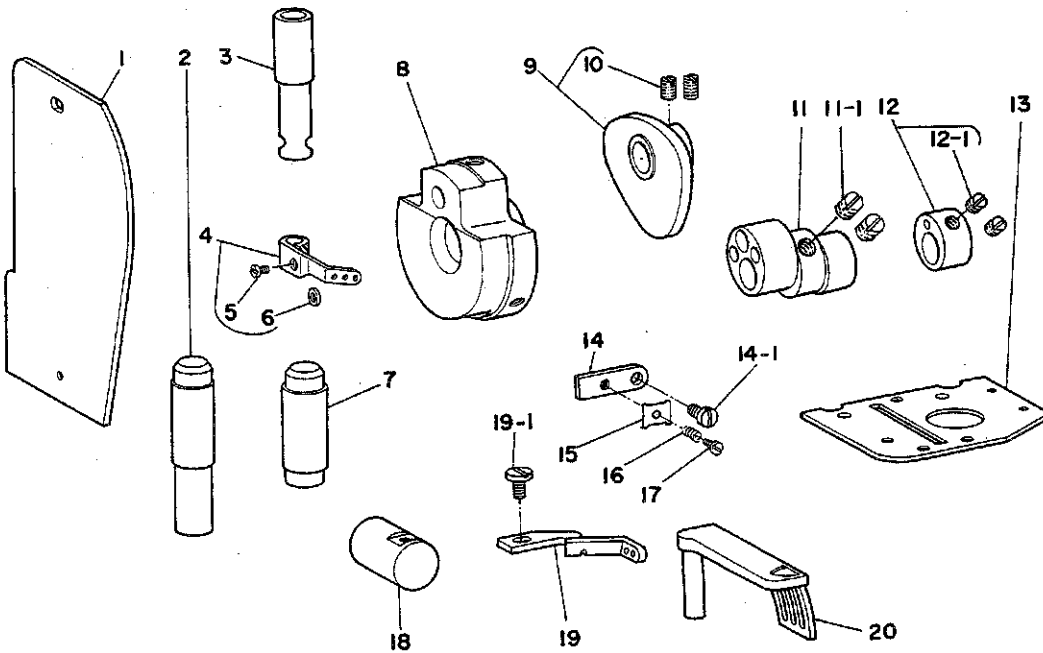

2. EXCLUSIVE PARTS FOR GAUGE 1/4" ゲージ1/4" 専用部品

3. EXCLUSIVE PARTS FOR GAUGE 5/16" ゲージ5/16" 専用部品

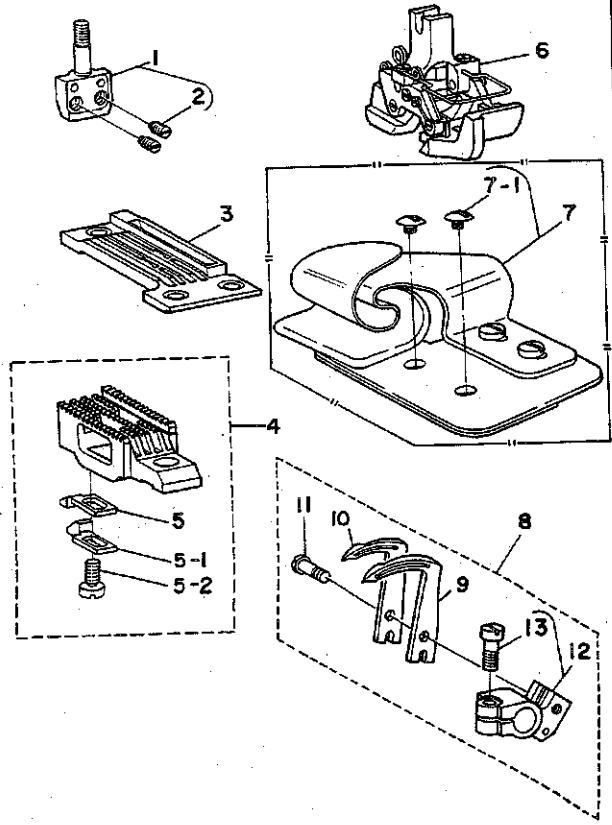
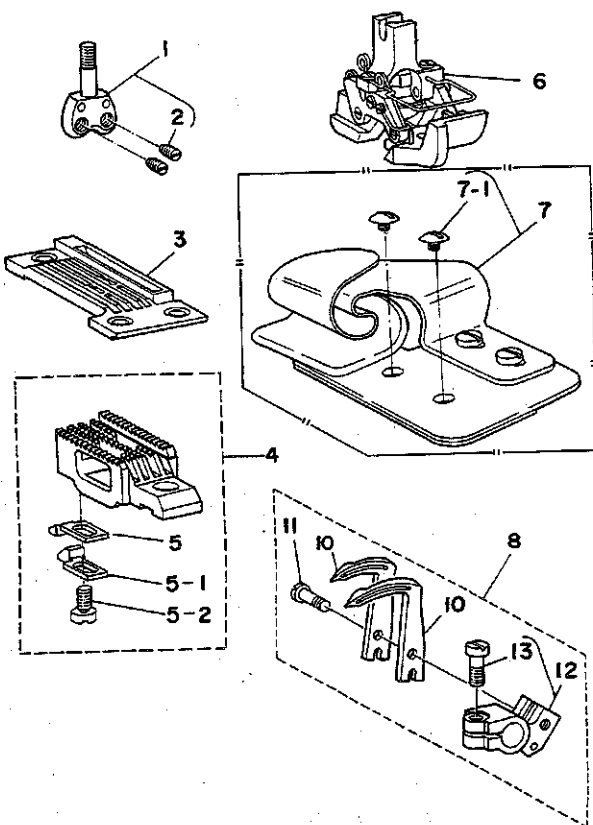

15. EXCLUSIVE PARTS FOR MODEL MS-26G

MS-26G 専用部品

1. COMMON PARTS FOR GAUGE 1/4", 5/16"

1/4"、5/16" 共通部品

Ref. No.	Note	Part No.	Description	E.C.	Amt. Req.
注記	品番			変更年月	数量
1		B3101-026-BOG	Face plate, upper		1
2		B1503-026-BOG	Presser bar bushing, lower		1
3		B1402-026-BOG	Needle bar bushing, upper		1
4		B1405-850-0B0	Needle bar thread eyelet asm.		1
5		SS-6090670-SP	Screw 9/64-40 L=6.0		(1)
6		WP-0480856-SP	Washer 4.8 x 8.4 x 0.8		(1)
7		B1404-026-BOG	Needle bar bushing, lower		1
8		B1207-026-BOG	Counterweight		1
9		B2210-026-OAG	Looper thread cam asm.		1
10		SS-8660330-SP	Screw 1/4-40 L=3.0		(2)
11		B2103-026-BOG	Feed rocker eccentric		1
11-1		SS-8660410-SP	Screw 1/4-40 L=4.0		2
12		B2006-026-BAG	Looper avoiding eccentric asm.		1
12-1		SS-8110410-TP	Screw 11/64-40 L=3.5		(2)
13		B2201-026-00G	Looper thread take-up stripper plate		1
14		B1170-026-00G	Thread tension disc retainer		1
14-1		SS-7090910-SP	Screw 9/64-40 L=8.5	A.2/77	1
15		B1134-850-000	Thread tension disc	D.5/78	—
		B1134-850-000-A	Thread tension disc	A.5/78	1
16		B1135-850-000	Tension spring (A)		1
17		SD-0380551-SL	Hinge screw D=3.80 H=5.5		1
18		B2509-026-BOG	Needle guard holder		1
19		B2510-026-BOG	Looper thread eyelet		1
19-1		SS-6090630-SP	Screw 9/64-40 L=6.0	A.2/77	1
20		B1122-026-BAG	Looper gate asm., right		1

2. EXCLUSIVE PARTS FOR GAUGE 1/4"

ゲージ1/4" 専用部品

Ref. No.	Note	Part No.	Description	E.C.	Amt. Req.
注記	品番			変更年月	数量
1		B1406-019-FA0	Needle clamp 1/4" asm.		1
2		SS-8110310-SP	Screw 11/64-40 L=2.8		(2)
3		B1108-026-F0G	Throat plate 1/4"		1
4		B1604-026-FAG	Feed dog 1/4" asm.		1
5		B2508-026-00G	Needle guard (B)		(1)
5-1		B2507-026-BOG	Needle guard (A)		(1)
5-2		SS-7110840-SP	Screw 11/64-40 L=6.8		(1)
6		B1507-026-FBG	Presser foot (FINGER GUARD) 1/4" asm.		1
7	002	B9100-026-HAG	Folder 5/16" asm.		1
7-1		SS-5090320-SP	Screw 9/64-40 L=3.2		(2)
8		B2513-026-FAG	Looper 1/4" asm.		1
9		B2513-026-F0G	Looper (A) 1/4"		1
10		B2515-026-F0G	Looper (C) 1/4"		1
11		SS-7091480-SP	Screw D=3.60 H=8.50		1
12		B2516-026-BA0	Looper holder asm.		1
13		SS-6111040-SP	Screw 11/64-40 L=9.5		1







3. EXCLUSIVE PARTS FOR GAUGE 5/16"

ゲージ5/16" 専用部品

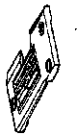
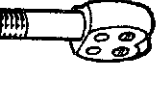
Ref. No.	Note	Part No.	Description	E.C.	Amt. Req.
注記	品番			変更年月	数量
1		B1406-026-HAG	Needle clamp 5/16" asm.		1
2		SS-8110310-SP	Screw 11/64-40 L=2.8		(2)
3		B1108-026-H0G	Throat plate 5/16"		1
4		B1604-026-HAG	Feed dog 5/16" asm.		1
5		B2508-026-00G	Needle guard (B)		(1)
5-1		B2507-026-BOG	Needle guard (A)		(1)
5-2		SS-7110840-SP	Screw 11/64-40 L=6.8		(1)
6		B1507-026-HBG	Presser foot (FINGER GUARD) asm.		1
7	002	B9100-026-HAG	Folder 5/16" asm.		1
7-1		SS-5090320-SP	Screw 9/64-40 L=3.2		(2)
8		B2513-026-HAG	Looper 5/16" asm.		1
9		B2513-026-H0G	Looper (A) 5/16"		(1)
10		B2515-026-H0G	Looper (C) 5/16"		(1)
11		SS-7091480-SP	Screw D=3.60 H=8.50		(1)
12		B2516-026-BA0	Looper holder asm.		(1)
13		SS-6111040-SP	Screw 11/64-40 L=9.5		(1)

Note (注記) 002 This is a folder which can sew 16-fold denim material of over 12.5 ounce weight (special order part) 12.5オンス以上のデニム16枚重縫い可能なフォルダーです。(特別注文部品)
 With the exception of frame, all parts, other than above parts are common use with Model MS-26. 上記以外の部品はフレーム除きMS-26と共通です。

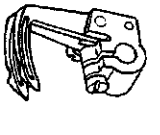
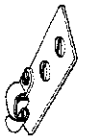
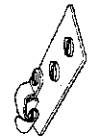
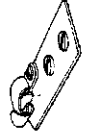
16. TABLE OF EXCHANGING GAUGES FOR MS-19
MS-19交換ゲージ一覧表

Description 品名	Gauges set (without folder) ゲージセット (フォルダーなし)	Throat plate 針板	Needle clamp asm. 針留メ	Presser foot asm. 押エ	Presser foot asm. (with finger guard) 押エ	Feed dog 送り番	Looper asm. ループ	Lap seam folder asm. フォルダー												
								M	G	MH	H									
Gauge components ゲージ関係	1 1/8" (3.2mm)	A	B	C	D	E	F	M	G	MH	H	H	I							
	2 5/32" (4mm)																			
	3 3/16" (4.8mm)												B1108-019-B00	B1406-019-BA0	B1507-019-BA0	*B1507-019-BB0	B1604-019-B00	B2513-019-BA0	B9100-019-BAA	B9100-019-BAB
	4 7/32" (5.6mm)												B1108-019-C00	B1406-019-CA0	B1507-019-CA0	*B1507-019-CB0	B1604-019-B00	B2513-019-CA0	B9100-019-CAA	B9100-019-CAB
	5 1/4" (6.4mm)												B1108-019-D00	B1406-019-DA0	B1507-019-DA0	*B1507-019-DB0	B1604-019-D00	B2513-019-DA0	B9100-019-DAA	B9100-019-DAB
	B1108-019-E00												B1406-019-EA0	B1507-019-EA0	*B1507-019-EB0	B1604-019-E00	B2513-019-EA0	B9100-019-EAA	B9100-019-EAB	
	B1108-019-F00	B1406-019-FA0	B1507-019-FA0	*B1507-019-FB0	B1604-019-F00	B2513-019-FA0	B9100-019-FAA	B9100-019-FAB	B9100-019-FAC											

Note (注記) * = Special order part 特別注文部品です

3/16" (4.8mm) is standard gauge. 3/16" (4.8mm) is標準ゲージです。

① Size code サイズ記号

1/8" (3.2mm) = B

5/32" (4mm) = C

3/16" (4.8mm) = D

7/32" (5.6mm) = E

1/4" (6.4mm) = F

② Binder code バインダー記号

M (For light weight materials 薄物用) = A

MH (For medium heavy weight materials 中厚物用) = B

H (For heavy weight materials 厚物用) = C

③ Looper components ループ関係

The size code goes into the mark Δ of the part number below, so please place your orders for the part number with size code. 下の品番△印にはサイズ記号が入りますのでサイズ記号を入れた品番でご注文下さい。

B2513-019-AA0 Looper asm. ループ (組)

B2513-019-A00 Looper A ループA

B2514-019-A00 Looper B ループB

Looper asm. ループ (組)

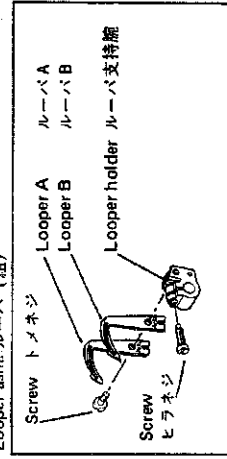

17. TABLE OF EXCHANGING GAUGES FOR MS-26
MS-26交換ゲージ一覧表

Description	Gauges set (without folder) ゲージセット (フォルダーなし)	Throat plate 針板	Needle clamp 針留メ (組)	Presser foot asm. 押エ (組)	Presser foot asm. (w/with finger guard) 押エ (組) (指ガード付)	Feed dog 送り歯	Looper asm. ループ (組)	Lap seam folder asm. フォルダー (組)					
								M	MH	H	I	H	XH
								G	H				J
Gauge components	3-needle	7/32" (5.6mm)	A	C	D	E	F	G	H	I	H	XH	
	1	B1108-026-EF0	B1406-026-EA0	B1507-026-EA0	*B1507-026-EB0	B1604-026-A00	B2513-026-EA0	B9100-026-FAA	B9100-026-EAB	B9100-026-EAC			
	2	B1108-026-FF0 B1108-026-FFZ B1108-026-F0C	B1406-026-FA0	B1507-026-FA0 B1507-026-FAC B1507-026-FBC	*B1507-026-FB0 B1507-026-FBC	B1604-026-A00 B1604-026-A0B	B2513-026-FA0	B9100-026-FAA	B9100-026-FAB	B9100-026-FAC	B9100-026-FAD		
	3	B1108-026-GF0	B1406-026-GA0	B1507-026-GA0	*B1507-026-GB0	B1604-026-A00	B2513-026-GA0	B9100-026-GAA	B9100-026-GAB	B9100-026-GAC			
	4	B1108-026-HF0	B1406-026-HA0	B1507-026-HA0	*B1507-026-HB0	B1604-026-B00	B2513-026-HA0	B9100-026-HAA	B9100-026-HAB	B9100-026-HAC			
	5	B1108-026-KF0	B1406-026-KA0	B1507-026-KA0	*B1507-026-KB0	B1604-026-B00	B2513-026-KA0	B9100-026-KAA	B9100-026-KAB	B9100-026-KAC			
	6	B1108-026-DF0	B1406-019-DA0	B1507-026-DA0	*B1507-026-DB0	B1604-026-D00	B2513-026-DA0	B9100-026-DA0	B9100-026-DAB	B9100-026-DAC			
2-needle	1/4" (6.4mm)		B										
7	*B1108-026-FEY	*B1406-026-FA0	*B1507-026-FAB	*B1507-026-FBB	B1604-026-A00	*B2513-026-FAB							

Note (注記) * = Special order part 特別注文部品です

◇ = Special parts for sewing glass fiber ガラス繊維製用
3-needle 1/4" (6.4mm) is standard gauge. 3本針 1/4" (6.4mm) は標準ゲージです。

- ① Size code サイズ記号
7/32" (5.6mm) = E
1/4" (6.4mm) = F
9/32" (7.2mm) = G
5/16" (8mm) = H
3/8" (9.6mm) = K
3/16" (4.8mm) = D

② Binder code バインダー記号

- M (For light weight materials 薄物用) = A
MH (For medium heavy weight materials 中厚物用) = B
H (For heavy weight materials 厚物用) = C
XH (For extra heavy weight materials 極厚物用) = D

The size code goes into the mark Δ of the part number below. 下の品番△の印にはサイズ記号を入
so please place your orders for the part number with size code. が入りますのでサイズ記号を入
れた品番でご注文下さい。



- B2513-026-AA0 Looper asm. ループ (組)
B2513-026-A00 Looper A
B2514-026-000 Looper B
B2515-026-A00 Looper C

In case of 3/16", looper A and looper C are used, except looper B
In this case, looper holder B2516-026-D00 and needle guide
B2507-026-D00 are used as exclusive parts.

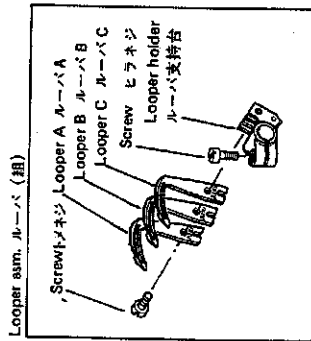
3/16" の場合にはループAとループCが使われます。
ループBを除いてループAとループCが併用されます。
それ以外、ループAとループCが併用されます。
ループBは専用部品B2507-026-D00と針案内B2516-026-D00の専用部
品が使われます。

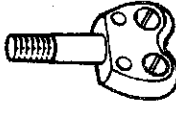
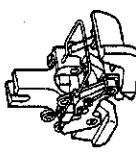
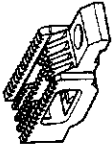
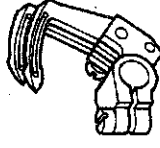

18. TABLE OF EXCHANGING GAUGES FOR MS-26G
MS-26G交換ゲージ一覧表

Description 品名	Gauge set (without folder) ゲージセット (フォルダーなし)	Throat plate 針板 A	Needle clamp asm. 針留メ (組) B	Presser foot asm. (with finger guard) 押エ (組) (指ガード付) C	Feed dog asm. 送り歯 (組) D	Looper asm. ルーパー (組) E	Lap seam folder asm. フォルダー (組) F
Gauge components ゲージ関係							
		B1108-026-FFX	B1108-026-F0G	B1406-019-FA0	B1507-026-FBG	B1604-026-FAG	B2513-026-FAG
	B1108-026-HFX	B1108-026-H0G	B1406-026-HAG	B1507-026-HBG	B1604-026-HAG	B2513-026-HAG	B9100-026-HAG

① Size code サイズ記号
1/4" (6.4mm) = F
5/16" (8mm) = H

Looper components ルーパー関係

The size code goes into the mark Δ of the part number below, so please place your orders for the part number with size code.

B2513-026-ΔAG Looper asm. ルーパー (組)
B2513-026-Δ0G Looper A ルーパーA
B2515-026-Δ0G Looper C ルーパーC

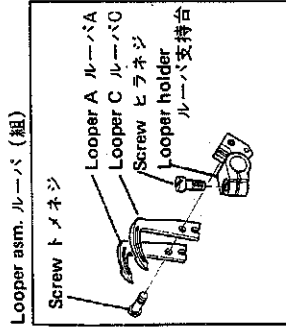

19. NUMERICAL INDEX OF PARTS

索引

Part No. 品番	Page 頁	Item Ref. 項目 No.	Part No. 品番	Page 頁	Item Ref. 項目 No.	Part No. 品番	Page 頁	Item Ref. 項目 No.	Part No. 品番	Page 頁	Item Ref. 項目 No.
EXCLUSIVE PARTS 專用部品			B1139-019-000	2	1 24	B1215-026-000	6	3 41	B1507-019-EB0	27	16 4-D
B1104-019-000	2	1 47	B1139-019-000	2	1 39	B1215-026-000	18	10 42	B1507-019-FA0	27	16 5-C
B1104-019-000	14	8 51	B1139-019-000	14	8 31	B1218-019-000	6	3 29	B1507-019-FB0	27	16 5-D
B1105-019-000	2	1 45	B1139-019-000	14	8 45	B1218-019-000	18	10 28	B1507-026-DA0	28	17 6-C
B1105-019-000	14	8 49	B1140-019-000	2	1 23	B1219-019-000	2	1 29	B1507-026-DB0	28	17 6-D
B1108-019-BF0	27	16 1-S	B1140-019-000	2	1 38	B1219-019-000	14	8 36	B1507-026-EA0	28	17 1-C
B1108-019-B00	27	16 1-A	B1140-019-000	14	8 30	B1220-019-000	6	3 30	B1507-026-EB0	28	17 1-D
B1108-019-CF0	27	16 2-S	B1140-019-000	14	8 44	B1220-019-000	18	10 29	B1507-026-FAB	28	17 7-C
B1108-019-C00	27	16 2-A	B1140-026-0A0	14	8 15	B1221-019-000	6	3 28	B1507-026-FAC	28	17 2-C-1
B1108-019-DF0	27	16 3-S	B1141-019-000	4	2 34	B1221-019-000	18	10 27	B1507-026-FA0	20	11 34
B1108-019-D00	10	6 28	B1141-019-000	16	9 35	B1222-019-000	6	3 32	B1507-026-FA0	28	17 2-C
B1108-019-D00	27	16 3-A	B1143-019-000	4	2 41	B1222-019-000	18	10 33	B1507-026-FBB	28	17 7-D
B1108-019-EF0	27	16 4-S	B1143-019-000	16	9 42	B1222-026-000	18	10 30	B1507-026-FBC	28	17 2-D-1
B1108-019-E00	27	16 4-A	B1143-026-0A0	14	8 13	B1222-026-000-A	18	10 30	B1507-026-FBG	26	15-2 6
B1108-019-FF0	27	16 5-S	B1144-019-0A0	4	2 42	B1401-019-000	6	3 1	B1507-026-FBG	29	18 1-C
B1108-019-F00	27	16 5-A	B1144-019-0A0	16	9 43	B1401-026-000	18	10 1	B1507-026-FB0	20	11 36
B1108-026-DF0	28	17 6-S	B1144-026-000	14	8 14	B1402-019-000	6	3 2	B1507-026-FB0	28	17 2-D
B1108-026-D00	28	17 6-A	B1146-019-000	2	1 11	B1402-026-B0G	26	15-1 3	B1507-026-GA0	28	17 3-C
B1108-026-EF0	28	17 1-S	B1148-019-000	2	1 42	B1402-026-000	18	10 2	B1507-026-GB0	28	17 3-D
B1108-026-E00	28	17 1-A	B1148-019-000	14	8 46	B1404-026-B0G	26	15-1 7	B1507-026-HA0	28	17 4-C
B1108-026-FFX	29	18 1-S	B1152-019-000	2	1 18	B1404-026-000	6	3 14	B1507-026-HBG	26	15-3 6
B1108-026-FFY	28	17 7-S	B1152-019-000	14	8 25	B1404-026-000	18	10 13	B1507-026-HBG	29	18 2-C
B1108-026-FFZ	28	17 2-S-1	B1155-019-000	2	1 7	B1405-850-0B0	26	15-1 4	B1507-026-HB0	28	17 4-D
B1108-026-FF0	28	17 2-S	B1155-019-000	14	8 7	B1406-019-BA0	27	16 1-B	B1507-026-KA0	28	17 5-C
B1108-026-F0B	28	17 7-A	B1156-019-000	2	1 19	B1406-019-CA0	27	16 2-B	B1507-026-KB0	28	17 5-D
B1108-026-F0C	28	17 2-A-1	B1156-019-000	14	8 26	B1406-019-DA0	6	3 15	B1601-019-000	12	7 34
B-1108-026-F0G	26	15-2 3	B1156-026-0A0	14	8 8	B1406-019-DA0	27	16 3-B	B1601-026-000	24	14 34
B1108-026-F0G	29	18 1-A	B1157-019-000	2	1 17	B1406-019-DA0	28	17 6-B	B1602-019-000	12	7 32
B1108-026-F00	22	13 28	B1157-019-000	14	8 24	B1406-019-EA0	27	16 4-B	B1602-019-000	24	14 32
B1108-026-F00	28	17 2-A	B1159-026-000	20	11 22	B1406-019-FA0	26	15-2 1	B1604-019-B00	27	16 1-E
B1108-026-GF0	28	17 3-S	B1160-019-0A0	10	6 19	B1406-019-FA0	27	16 5-B	B1604-019-B00	27	16 2-E
B1108-026-G00	28	17 3-A	B1161-012-000	8	4 5	B1406-019-FA0	29	18 1-B	B1604-019-D00	12	7 52
B1108-026-HFX	29	18 2-S	B1161-012-000	20	11 5	B1406-026-EA0	28	17 1-B	B1604-019-D00	27	16 3-E
B1108-026-HF0	28	17 4-S	B1161-026-000	20	11 24	B1406-026-FA0	18	10 14	B1604-019-E00	27	16 4-E
B1108-026-H0G	26	15-3 3	B1162-019-0A0	10	6 20	B1406-026-FA0	28	17 2-B	B1604-019-F00	27	16 5-E
B1108-026-H0G	29	18 2-A	B1162-026-0A0	20	11 26	B1406-026-FA0	28	17 7-B	B1604-026-A0B	28	17 2-E-1
B1108-026-H00	28	17 4-A	B1164-026-000	20	11 28	B1406-026-GA0	28	17 3-B	B1604-026-A0H	24	14 55
B1108-026-KF0	28	17 5-S	B1165-026-000	20	11 29	B1406-026-HAG	26	15-3 1	B1604-026-A00	24	14 53
B1108-026-K00	28	17 5-A	B1166-019-000	10	6 13	B1406-026-HAG	29	18 2-B	B1604-026-A00	28	17 1-E
B1110-019-000	2	1 25	B1167-019-000	10	6 21	B1406-026-HA0	28	17 4-B	B1604-026-A00	28	17 2-E
B1110-026-000	14	8 32	B1170-026-00G	26	15-1 14	B1406-026-KA0	28	17 5-B	B1604-026-A00	28	17 3-E
B1111-019-000	2	1 31	B1179-552-000	2	1 6	B1408-019-0A0	6	3 23	B1604-026-A00	28	17 7-E
B1111-019-000	14	8 38	B1179-552-000	14	8 6	B1408-019-0A0	18	10 22	B1604-026-B0H	24	14 56
B1113-019-000	4	2 30	B1201-019-000	6	3 31	B1409-019-0B0	6	3 11	B1604-026-B00	28	17 4-E
B1113-019-000	16	9 31	B1201-026-000	18	10 32	B1409-019-0B0	18	10 10	B1604-026-B00	28	17 5-E
B1114-019-000	4	2 31	B1202-019-000	6	3 35	B1411-019-000	6	3 26	B1604-026-D00	28	17 6-E
B1114-019-000	16	9 32	B1202-019-000	8	4 38	B1411-019-000	18	10 25	B1604-026-FAG	26	15-2 4
B1115-019-000	4	2 33	B1202-019-000	18	10 36	B1412-038-000	6	3 25	B1604-026-FAG	29	18 1-D
B1115-019-000	16	9 34	B1202-019-000	20	11 47	B1412-038-000	18	10 24	B1604-026-HAG	26	15-3 4
B1116-019-0A0	2	1 33	B1203-019-0A0	6	3 36	B1418-019-000	6	3 13	B1604-026-HAG	29	18 2-D
B1116-026-0A0	14	8 40	B1203-019-0A0	18	10 37	B1418-019-000	18	10 12	B1606-019-000	12	7 33
B1117-019-000	2	1 30	B1204-019-000	6	3 34	B1501-019-000	8	4 18	B1606-019-000	24	14 33
B1117-019-000	14	8 37	B1204-019-000	18	10 35	B1501-019-000	20	11 18	B1607-019-000	12	7 31
B1119-019-000	2	1 34	B1207-019-0A0-A	6	3 18	B1502-019-000	8	4 19	B1607-019-000	12	7 49
B1119-026-000	14	8 41	B1207-019-000	6	3 19	B1502-019-000	20	11 19	B1607-019-000	24	14 31
B1120-019-000	2	1 40	B1207-026-B0G	26	15-1 8	B1503-026-B0G	26	15-1 2	B1607-019-000	24	14 50
B1122-026-BAG	26	15-1 20	B1207-026-0A0	18	10 17	B1503-026-000	8	4 24	B1608-019-000	12	7 36
B1122-026-0A0	22	13 20	B1207-026-000	18	10 18	B1503-026-000	20	11 33	B1608-026-000	24	14 36
B1125-026-0A0	22	13 21	B1208-019-000	6	3 22	B1504-019-0A0	8	4 22	B1610-019-000	12	7 35
B1127-026-000	22	13 14	B1208-019-000	18	10 21	B1504-019-0A0	20	11 31	B1610-019-000	24	14 35
B1130-026-000	22	13 22	B1209-019-0A0	6	3 24	B1506-019-000	8	4 21	B1611-019-0A0	12	7 40
B1130-051-000	2	1 15	B1209-019-0A0	18	10 23	B1506-019-000	20	11 21	B1611-019-0A0	24	14 41
B1130-051-000	14	8 22	B1211-019-000	6	3 39	B1507-019-BA0	27	16 1-C	B1614-019-000	12	7 41
B1131-026-000	22	13 23	B1211-019-000	18	10 40	B1507-019-BB0	27	16 1-D	B1614-019-000	24	14 42
B1134-019-000	2	1 37	B1212-019-000	8	4 42	B1507-019-CA0	27	16 2-C	B1617-019-000	12	7 37
B1134-019-000	14	8 43	B1212-019-000	20	11 51	B1507-019-CB0	27	16 2-D	B1617-019-000	24	14 37
B1134-850-000	26	15-1 15	B1214-019-000	6	3 38	B1507-019-DA0	8	4 25	B1801-019-000	8	4 34
B1134-850-000-A	26	15-1 15	B1214-019-000	8	4 41	B1507-019-DA0	27	16 3-C	B1801-026-000	20	11 43
B1135-019-000	10	6 22	B1214-019-000	18	10 39	B1507-019-DB0	8	4 27	B1802-019-000	8	4 28
B1135-850-000	26	15-1 16	B1214-019-000	20	11 50	B1507-019-DB0	27	16 3-D	B1802-019-000	20	11 37
B1137-019-000	10	6 23				B1507-019-EA0	27	16 4-C			

Part No.	Page	Item	Ref.	Part No.	Page	Item	Ref.	Part No.	Page	Item	Ref.	Part No.	Page	Item	Ref.
品番	頁	項目	No.	品番	頁	項目	No.	品番	頁	項目	No.	品番	頁	項目	No.
B1803-019-000	8	4	29	B2208-019-000	16	9	2	B2413-019-000	16	9	25	B2514-019-D00	10	6	3
B1803-019-000	20	11	38	B2210-019-0A0	8	4	32	B2413-026-A00	4	2	36	B2514-026-000	22	13	3
B1805-019-000	2	1	20	B2210-019-0A0	20	11	41	B2413-026-A00	16	9	37	B2515-019-0A0	10	6	5
B1805-019-000	14	8	27	B2210-026-0AG	26	15-1	9	B2413-026-B00	4	2	38	B2515-026-F0G	26	15-2	10
B1806-019-000	2	1	22	B2211-026-000	16	9	21	B2413-026-B00	16	9	39	B2515-026-F00	22	13	4
B1806-019-000	14	8	29	B2212-019-000	4	2	15	B2414-019-0A0	4	2	28	B2515-026-H0G	26	15-3	10
B1808-019-000	8	4	30	B2212-019-000	16	9	15	B2414-019-0A0	16	9	29	B2516-026-BA0	26	15-2	12
B1808-019-000	20	11	39	B2212-026-000	4	2	18	B2414-026-000	4	2	40	B2516-026-BA0	26	15-3	12
B1810-026-0A0	8	4	39	B2212-026-000	16	9	18	B2414-026-000	16	9	41	B2516-026-0A0	22	13	6
B1810-026-0A0	20	11	48	B2213-019-000	4	2	13	B2415-019-000	4	2	27	B2518-026-000	22	13	5
B1811-019-000	8	4	37	B2213-019-000	16	9	13	B2415-019-000	16	9	28	B3101-019-000	2	1	1
B1811-019-000	20	11	46	B2213-038-000	4	2	22	B2416-019-000	4	2	23	B3101-026-B0G	26	15-1	1
B1901-019-000	6	3	4	B2213-038-000	16	9	23	B2416-019-000	16	9	24	B3101-026-000	14	8	1
B1901-019-000	18	10	5	B2216-026-000	4	2	11	B2416-019-000	9	5	15	B3102-019-000	2	1	3
B1903-019-000	2	1	8	B2216-026-000	16	9	11	B2421-019-000	9	5	16	B3102-019-000	14	8	3
B1903-026-000	14	8	10	B2224-019-000	4	2	4	B2421-019-000	21	12	16	B3103-019-000	2	1	5
B1904-019-000	2	1	9	B2224-019-000	16	9	4	B2421-026-0A0	4	2	25	B3103-019-000	14	8	5
B1904-019-000	14	8	11	B2226-019-000	4	2	5	B2421-026-0A0	16	9	26	B3104-019-000	2	1	13
B1906-019-000	6	3	9	B2226-019-000	16	9	5	B2431-026-000	21	12	15	B3104-019-000	14	8	20
B1906-026-000	18	10	7	B2301-019-000	9	5	2	B2501-019-000	12	7	14	B3106-019-000	2	1	2
B1908-019-000	6	3	6	B2301-026-000	21	12	2	B2501-026-000	24	14	11	B3106-019-000	14	8	2
B1910-019-000	6	3	7	B2303-019-000	9	5	1	B2502-019-000	12	7	15	B3126-012-000	9	5	8
B1910-019-000	18	10	8	B2303-026-000	21	12	1	B2502-019-000	24	14	12	B3126-012-000	21	12	8
B2001-019-000	12	7	48	B2306-019-000	9	5	5	B2503-019-000	12	7	19	B3132-012-000	9	5	9
B2001-026-0B0	24	14	47	B2306-019-000	21	12	5	B2503-019-000	24	14	19	B3132-012-000	21	12	9
B2001-026-0C0	24	14	46	B2307-019-000	9	5	6	B2505-019-0A0	12	7	17	B3501-019-0A0	6	3	44
B2002-026-000-A	24	14	49	B2307-019-000	21	12	6	B2505-019-0A0	24	14	17	B3501-019-0A0	18	10	45
B2004-019-0A0	12	7	46	B2310-019-000	9	5	7	B2507-019-BA0	10	6	15	B3501-019-000	6	3	45
B2004-019-0B0	12	7	45	B2310-019-000	21	12	7	B2507-019-CA0	10	6	18-1	B3501-019-000	18	10	46
B2006-019-000	12	7	50	B2311-019-000	9	5	11	B2507-019-B00	10	6	16	B3502-019-000	6	3	50
B2006-019-000	24	14	51	B2311-019-000	21	12	11	B2507-019-C00	10	6	18-2	B3502-019-000	18	10	51
B2006-026-B0G	26	15-1	12	B2312-019-000	9	5	12	B2507-019-000	10	6	7	B3503-019-000	6	3	49
B2101-019-000	12	7	21	B2312-019-000	21	12	12	B2507-026-B0G	26	15-2	5-1	B3503-019-000	18	10	50
B2101-026-000	24	14	21	B2313-019-000	9	5	10	B2507-026-B0G	26	15-3	5-1	B3504-019-000	6	3	51
B2102-019-000	12	7	4	B2313-019-000	21	12	10	B2507-026-CA0	22	13	16	B3504-019-000	18	10	52
B2102-026-0A0	24	14	1	B2314-019-000	9	5	13	B2507-026-C00	22	13	17	B3505-019-000	6	3	43
B2103-019-000	12	7	29	B2314-019-000	21	12	13	B2507-026-000	22	13	8	B3505-019-000	18	10	44
B2103-026-B0G	26	15-1	11	B2315-019-000	8	4	14	B2508-019-A00	10	6	18-3	B3508-019-000	6	3	46
B2103-026-000	24	14	29	B2315-019-000	20	11	14	B2508-019-000	10	6	18	B3508-019-000	18	10	47
B2105-019-000	12	7	26	B2317-019-000	8	4	16	B2508-026-00G	26	15-2	5	B3510-019-000	6	3	52
B2105-019-000	24	14	26	B2317-019-000	20	11	16	B2508-026-00G	26	15-3	5	B3510-019-000	18	10	53
B2106-019-000	12	7	24	B2319-019-000	8	4	9	B2509-019-000	22	13	19	B3701-019-000	8	4	11
B2106-026-000	24	14	24	B2319-019-000	20	11	9	B2509-019-000	10	6	10	B9100-019-000	20	11	11
B2107-019-000	12	7	7	B2321-019-000	8	4	10	B2509-019-000	22	13	11	B9100-019-BAA	27	16	1-G
B2107-019-000	24	14	4	B2321-019-000	20	11	10	B2509-026-B0G	26	15-1	18	B9100-019-BAB	27	16	1-H
B2108-019-000	12	7	27	B2322-019-000	8	4	12	B2510-019-000	10	6	8	B9100-019-CAA	27	16	2-G
B2108-026-000	24	14	27	B2322-019-000	20	11	12	B2510-026-B0G	26	15-1	19	B9100-019-CAB	27	16	2-H
B2109-019-0A0	12	7	1	B2324-019-000	8	4	6	B2510-026-000	22	13	9	B9100-019-DAA	27	16	3-G
B2115-019-0B0	12	7	11	B2324-019-000	20	11	6	B2513-019-BA0	27	16	1-F	B9100-019-DAB	10	6	25
B2115-019-0B0	24	14	8	B2326-019-000	8	4	7	B2513-019-CA0	27	16	2-F	B9100-019-DAB	27	16	3-H
B2116-019-000	12	7	12	B2326-019-000	20	11	7	B2513-019-DA0	10	6	1	B9100-019-DAC	27	16	3-i
B2116-019-000	24	14	9	B2327-019-000	8	4	1	B2513-019-DA0	27	16	3-F	B9100-019-EAA	27	16	4-G
B2117-019-000	12	7	5	B2327-019-000	20	11	1	B2513-019-D00	10	6	2	B9100-019-EAB	27	16	4-H
B2117-019-000	12	7	22	B2328-019-000	8	4	2	B2513-019-EA0	27	16	4-F	B9100-019-EAC	27	16	4-i
B2117-019-000	24	14	3	B2328-019-000	20	11	2	B2513-019-FA0	27	16	5-F	B9100-019-FAA	27	16	5-G
B2117-019-000	24	14	22	B2329-019-000	8	4	3	B2513-026-DA0	28	17	6-F	B9100-019-FAB	27	16	5-H
B2122-019-000	12	7	9	B2329-019-000	20	11	3	B2513-026-EA0	28	17	1-F	B9100-019-FAC	27	16	5-i
B2122-019-000	24	14	6	B2330-019-000	8	4	4	B2513-026-FAB	28	17	7-F	B9100-026-DAA	28	17	6-G
B2123-026-0A0	24	14	14	B2330-019-000	20	11	4	B2513-026-FAG	26	15-2	8	B9100-026-DAB	28	17	6-H
B2201-019-000	4	2	8	B2401-019-000	9	5	22	B2513-026-FAG	29	18	1-E	B9100-026-DAC	28	17	6-i
B2201-019-000	16	9	8	B2401-026-000	21	12	26	B2513-026-FA0	22	13	1	B9100-026-EAB	28	17	1-H
B2201-026-00G	26	15-1	13	B2402-019-000	9	5	18	B2513-026-FA0	28	17	2-F	B9100-026-EAC	28	17	1-i
B2202-019-000	4	2	9	B2402-019-000	21	12	18	B2513-026-F0G	26	15-2	9	B9100-026-FAA	28	17	2-G
B2202-019-000	16	9	9	B2404-019-000	9	5	20	B2513-026-F00	22	13	2	B9100-026-FAB	22	13	25
B2203-019-000	4	2	6	B2405-026-000	21	12	23	B2513-026-GA0	28	17	3-F	B9100-026-FAB	28	17	2-H
B2203-019-000	16	9	6	B2406-019-0B0	2	1	27	B2513-026-HAG	26	15-3	8	B9100-026-FAB	28	17	7-H
B2207-026-000	4	2	1	B2406-026-000	21	12	20	B2513-026-HAG	29	18	2-E	B9100-026-FAC	28	17	2-i
B2207-026-000	16	9	1	B2409-026-0B0	14	8	34	B2513-026-HA0	28	17	4-F	B9100-026-FAC	28	17	7-i
B2208-019-000	4	2	2	B2413-019-000	4	2	24	B2513-026-H0G	26	15-3	9	B9100-026-FAD	28	17	2-J
				B2413-019-000	14	8	17	B2513-026-KA0	28	17	5-F	B9100-026-GAA	28	17	3-G

Part No. 品番	Page 頁	Item Ref. 項目 No.	Part No. 品番	Page 頁	Item Ref. 項目 No.	Part No. 品番	Page 頁	Item Ref. 項目 No.	Part No. 品番	Page 頁	Item Ref. 項目 No.	Part No. 品番	Page 頁	Item Ref. 項目 No.	
B9100-026-GAB	28	17	3-H	SS-4080610-SP	22	13	10	SS-7090520-SP	16	9	14	SS-8110310-SP	26	15-2	2
B9100-026-GAC	28	17	3-i	SS-4090610-SP	2	1	12	SS-7090520-SP	21	12	21	SS-8110310-SP	26	15-3	2
B9100-026-HAA	28	17	4-G	SS-4091010-SP	2	1	28	SS-7090530-SP	4	2	12	SS-8110320-SP	8	4	31
B9100-026-HAB	28	17	4-H	SS-4091010-SP	14	8	35	SS-7090530-SP	4	2	14	SS-8110320-SP	20	11	40
B9100-026-HAC	28	17	4-i	SS-4091010-SP	20	11	27	SS-7090530-SP	4	2	20	SS-8110410-TP	12	7	51
B9100-026-HAG	26	15-2	7	SS-4091010-SP	21	12	22	SS-7090530-SP	16	9	14	SS-8110410-TP	24	14	52
B9100-026-HAG	26	15-3	7	SS-4622340-SP	9	5	14	SS-7090530-SP	16	9	20	SS-8110410-TP	26	15-1	12-1
B9100-026-HAG	29	18	1-F	SS-4622340-SP	21	12	14	SS-7090540-TP	12	7	43	SS-8110510-SP	12	7	28
B9100-026-HAG	29	18	2-F	SS-5060410-SP	9	5	19	SS-7090540-TP	24	14	44	SS-8110510-SP	24	14	28
B9100-026-KAA	28	17	5-G	SS-5060410-SP	21	12	19	SS-7090710-SP	2	1	10	SS-8111160-SP	9	5	3
B9100-026-KAB	28	17	5-H	SS-5060410-SP	21	12	24	SS-7090710-SP	4	2	17	SS-8111160-SP	21	12	3
B9100-026-KAC	28	17	5-i	SS-5090320-SP	10	6	26	SS-7090710-SP	16	9	12	SS-8150310-SP	6	3	3
B9105-019-000	10	6	27	SS-5090320-SP	22	13	26	SS-7090710-SP	16	9	17	SS-8150310-SP	8	4	20
B9105-026-000	22	13	27	SS-5090320-SP	26	15-2	7-1	SS-7090710-SP	16	9	22	SS-8150310-SP	18	10	3
				SS-5090320-SP	26	15-3	7-1	SS-7090710-SP	20	11	30	SS-8150310-SP	20	11	20
OIL WICK			油心	SS-5090710-SP	20	11	25	SS-7090710-SP	21	12	27	SS-8150310-SP	24	14	20
CQ-2020000-00	12	7	13	SS-5091020-SP	2	1	36	SS-7090710-SP	22	13	15	SS-8150410-SP	10	6	11
CQ-2020000-00	24	14	10	SS-5091020-SP	14	8	42	SS-7090850-SP	2	1	35	SS-8150410-SP	12	7	20
CQ-3000000-00	14	8	9	SS-5660440-SP	6	3	47	SS-7090910-SP	6	3	12	SS-8150410-SP	12	7	25
CQ-3000000-00	18	10	4	SS-5660440-SP	18	10	48	SS-7090910-SP	18	10	11	SS-8150410-SP	18	10	31
				SS-5820540-SP	2	1	24	SS-7090910-SP	26	15-1	14-1	SS-8150410-SP	20	11	23
NEEDLE			針	SS-5820540-SP	2	1	39	SS-7090910-TP	6	3	5	SS-8150410-SP	22	13	12
MTV-100B1600	6	3	17	SS-5820540-SP	14	8	31	SS-7090910-TP	18	10	6	SS-8150410-SP	24	14	25
MTV-500B1900	18	10	16	SS-5820540-SP	14	8	45	SS-7090920-SP	12	7	2	SS-8150710-SP	12	7	8
MTV-500B2104	18	10	16	SS-6060210-SP	4	2	3	SS-7090920-SP	24	14	2	SS-8150710-SP	24	14	5
				SS-6060210-SP	16	9	3	SS-7091110-SP	4	2	32	SS-8151150-SP	4	2	26
NUT			ナット	SS-6060340-SP	4	2	10	SS-7091110-SP	8	4	26	SS-8151150-SP	12	7	16
NS-6110310-SP	9	5	4	SS-6060340-SP	16	9	10	SS-7091110-SP	16	9	33	SS-8151150-SP	12	7	38
NS-6110310-SP	21	12	4	SS-6080610-TP	22	13	18	SS-7091110-SP	20	11	35	SS-8151150-SP	12	7	44
NS-6110420-SP	14	8	19	SS-6080710-SP	10	6	9	SS-7091480-SP	10	6	4	SS-8151150-SP	16	9	27
NS-6120310-SP	8	4	8	SS-6080710-SP	22	13	10	SS-7091480-SP	26	15-2	11	SS-8151150-SP	24	14	13
NS-6120310-SP	20	11	8	SS-6090620-SP	2	1	21	SS-7091480-SP	26	15-3	11	SS-8151150-SP	24	14	38
NS-6150320-SP	12	7	6	SS-6090620-SP	14	8	28	SS-7092360-SP	10	6	12	SS-8151150-SP	24	14	45
NS-6150320-SP	24	14	16	SS-6090630-SP	4	2	29	SS-7092360-SP	22	13	13	SS-8152030-SP	6	3	42
NS-6150320-SP	24	14	39	SS-6090630-SP	14	8	12	SS-7110710-SP	8	4	17	SS-8152030-SP	18	10	43
				SS-6090630-SP	16	9	30	SS-7110710-SP	19	6	14	SS-8660330-SP	8	4	33
RUBBER RING			0 リング	SS-6090630-SP	26	15-1	19-1	SS-7110710-SP	20	11	17	SS-8660330-SP	20	11	42
RO-0952001-00	12	7	23	SS-6090670-SP	26	15-1	5	SS-7110830-SP	8	4	35	SS-8660330-SP	26	15-1	10
RO-0952001-00	24	14	23	SS-6092120-SP	6	3	48	SS-7110830-SP	12	7	10	SS-8660410-SP	12	7	30
				SS-6092120-SP	18	10	49	SS-7110830-SP	20	11	44	SS-8660410-SP	18	10	20
HINGE SCREW			段ネジ	SS-6111040-SP	10	6	6	SS-7110830-SP	24	14	7	SS-8660410-SP	24	14	30
SD-0280401-SL	6	3	8	SS-6111040-SP	22	13	7	SS-7110840-SP	26	15-2	5-2	SS-8660410-SP	26	15-1	11-1
SD-0280401-SL	18	10	9	SS-6111040-SP	26	15-2	13	SS-7110840-SP	26	15-3	5-2	SS-8660610-TP	2	1	26
SD-0380551-SL	26	15-1	17	SS-6111040-SP	26	15-3	13	SS-7111110-TP	8	4	23	SS-8660610-TP	6	3	21
SD-0450211-SP	8	4	15	SS-6151220-SP	6	3	20	SS-7111110-TP	12	7	3	SS-8660610-TP	14	8	33
SD-0450211-SP	20	11	15	SS-6151220-SP	14	8	16	SS-7111110-TP	12	7	18	SS-8701140-SP	6	3	37
SD-0790431-SP	8	4	13	SS-6151220-SP	18	10	19	SS-7111110-TP	12	7	39	SS-8701140-SP	8	4	40
SD-0790431-SP	20	11	13	SS-6151440-SN	2	1	43	SS-7111110-TP	12	7	47	SS-8701140-SP	18	10	38
				SS-6151440-SN	14	8	47	SS-7111110-TP	20	11	32	SS-8701140-SP	20	11	49
SCREW			止ネジ	SS-6151440-SP	2	1	48	SS-7111110-TP	24	14	15	SS-9150860-SP	6	3	40
SK-3552000-SC	2	1	44	SS-6151440-SP	14	8	52	SS-7111110-TP	24	14	18	SS-9150860-SP	8	4	43
SK-3552000-SC	14	8	48	SS-7060310-SP	2	1	14	SS-7111110-TP	24	14	40	SS-9150860-SP	18	10	41
SS-1090920-SP	2	1	4	SS-7060310-SP	2	1	41	SS-7111110-TP	24	14	48	SS-9150860-SP	20	11	52
SS-1090920-SP	14	8	4	SS-7060310-SP	4	2	37	SS-7120910-SP	6	3	27	SS-9284043-CP	2	1	46
SS-2060310-SP	16	9	38	SS-7060310-SP	14	8	21	SS-7120910-SP	18	10	26	SS-9284043-CP	14	8	50
SS-2060510-SP	21	12	25	SS-7060510-SP	4	2	35	SS-7151210-SP	2	1	32				
SS-2090710-SP	2	1	16	SS-7060510-SP	16	9	36	SS-7151210-SP	14	8	39	WASHER			座金
SS-2090710-SP	14	8	23	SS-7060510-SP	21	12	19	SS-7161040-SP	8	4	36	WP-0371016-SD	4	2	16
SS-2110920-SP	10	6	29	SS-7060610-SP	4	2	35	SS-7161040-SP	20	11	45	WP-0371016-SD	4	2	19
SS-2110920-SP	22	13	29	SS-7060610-SP	16	9	36	SS-7621040-SP	12	7	53	WP-0371016-SD	16	9	16
SS-3060410-SP	6	3	10	SS-7080510-SP	10	6	17	SS-7621040-SP	24	14	54	WP-0371016-SD	16	9	19
SS-3060710-SP	10	6	24	SS-7080510-SP	10	6	18-4	SS-7740740-SP	6	3	33	WP-0480856-SP	12	7	42
SS-3060710-SP	22	13	24	SS-7090410-SP	4	2	21	SS-7740740-SP	18	10	34	WP-0480856-SP	14	8	18
SS-3090510-SP	4	2	7	SS-7090510-SP	9	5	17	SS-8110310-SP	6	3	16	WP-0480856-SP	24	14	43
SS-3090510-SP	16	9	7	SS-7090510-SP	21	12	17	SS-8110310-SP	18	10	15	WP-0480856-SP	26	15-1	6
SS-3090710-TP	4	2	39	SS-7090520-SP	4	2	12								
SS-3090710-TP	16	9	40	SS-7090520-SP	4	2	14								
SS-4080610-SP	10	6	9	SS-7090520-SP	9	5	21								

M E M O

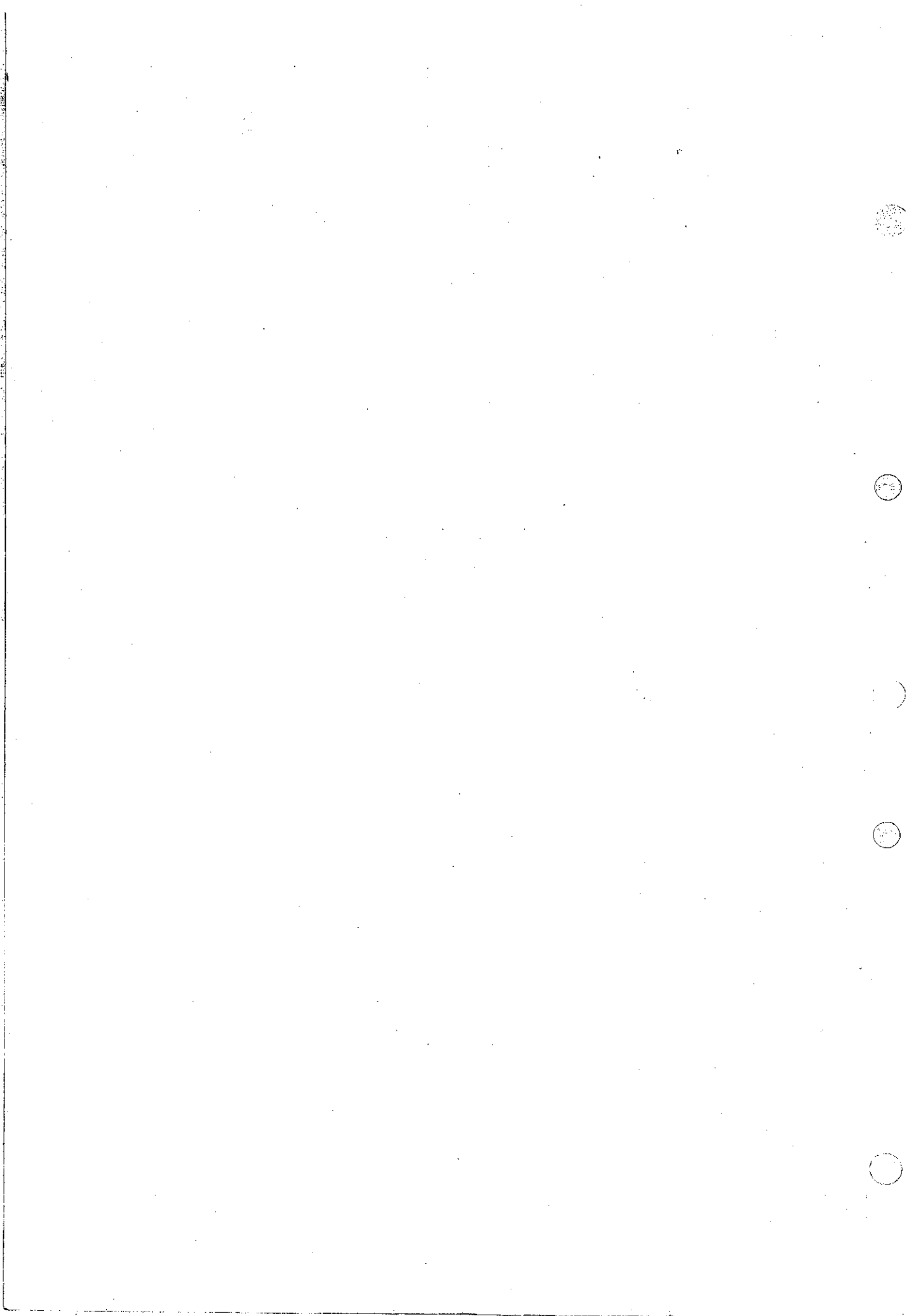

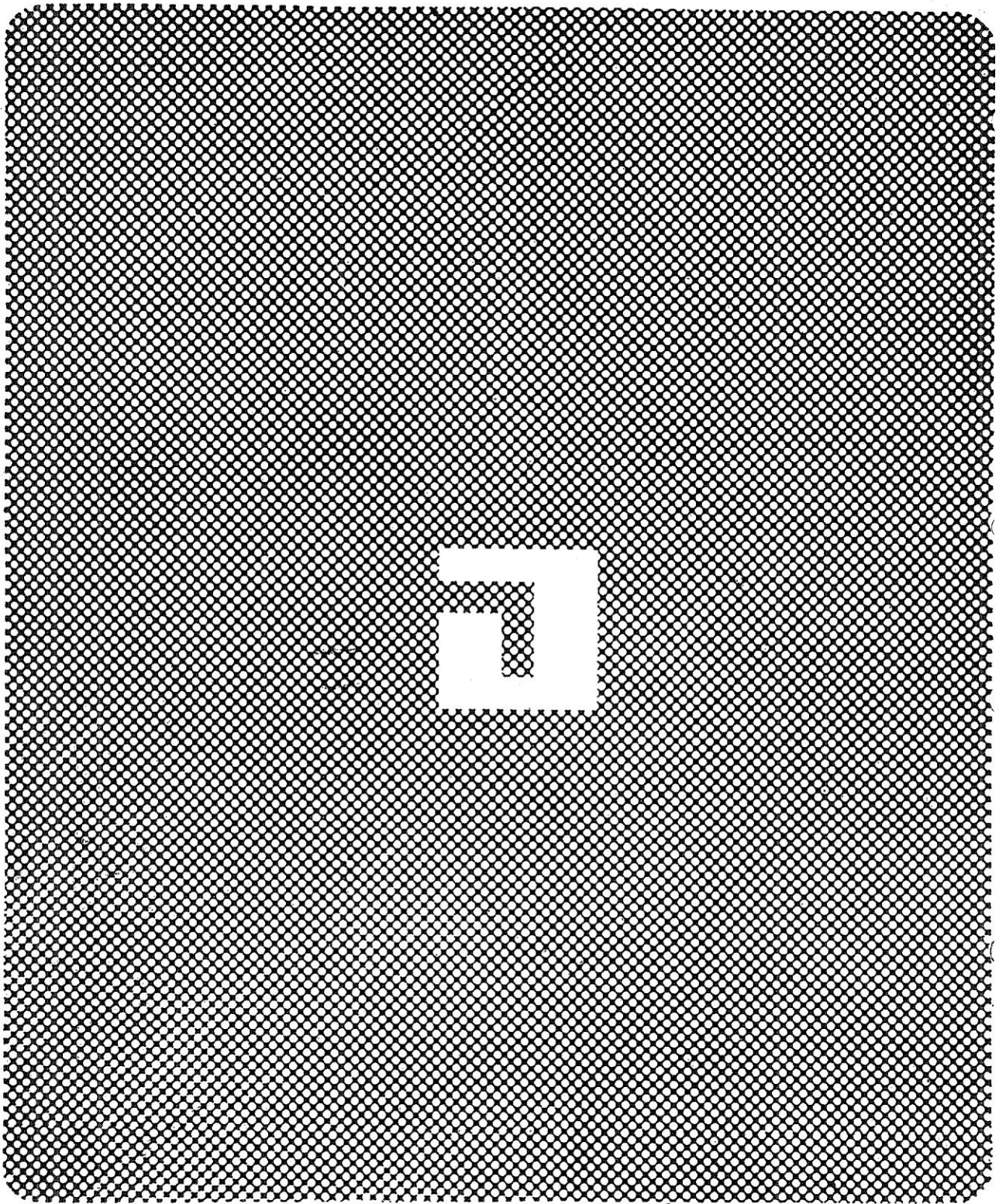

JUKI
TOKYO JUKI INDUSTRIAL CO., LTD.

東京重機工業株式会社